

BAILEY MULTI-SLOT TRACK – MST 250

THE STRENGTH WITHIN



BAILEY[®]

MONTREAL • TORONTO • CALGARY • EDMONTON • VANCOUVER

MULTI-SLOT TRACK

MST 250

The BAILEY MULTI-SLOT TRACK is an economical deflection system designed to provide complete flexibility.

- Allows for fast, easy and flexible stud installation
- Pre-punched 1 1/2" slots are spaced 1" O.C. to accommodate any stud spacing
- 2 1/2" leg height for added strength and improved performance
- Reduces required material
- Reduces labour costs
- Can be used with the Bailey TDC Clips to increase the load capacity of the track

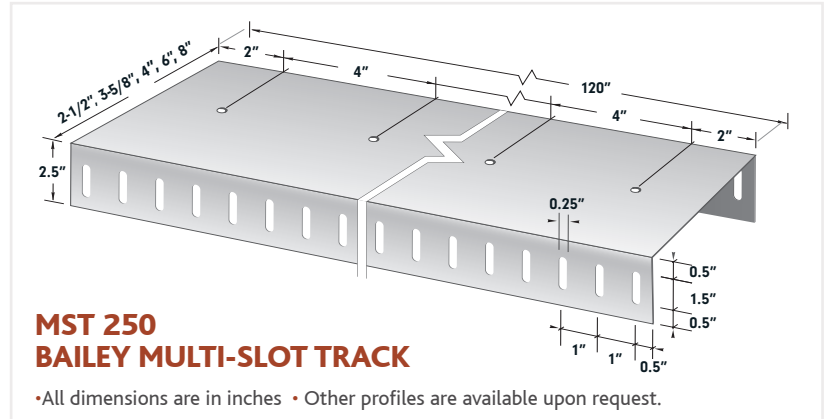

BAILEY MST 250 PROPERTIES

Product Identification	Base Steel Thickness		Size		Weight*	Mass*	Yield Stress**	Coating***	
	Mils (Colour)	Design		in.					mm
		in.	mm		lb/ft	kg/m			
250 MST 250 - 18	18 No Colour	0.0188	0.478	2-1/2	63.5	0.457	0.681	33	G40
362 MST 250 - 18				3-5/8	92.1	0.533	0.794		
400 MST 250 - 18				4	102	0.558	0.831		
600 MST 250 - 18				6	152	0.693	1.03		
250 MST 250 - 33	33 White	0.0346	0.879	2-1/2	63.5	0.822	1.22	33	G60 min
362 MST 250 - 33				3-5/8	92.1	0.959	1.43		
400 MST 250 - 33				4	102	1.00	1.49		
600 MST 250 - 33				6	152	1.25	1.85		
800 MST 250 - 33				8	203	1.49	2.21		
362 MST 250 - 43	43 Yellow	0.0451	1.15	3-5/8	92.1	1.24	1.85	33	G60 min
400 MST 250 - 43				4	102	1.30	1.93		
600 MST 250 - 43				6	152	1.61	2.40		
800 MST 250 - 43				8	203	1.93	2.87		
362 MST 250 - 54	54 Green	0.0566	1.44	3-5/8	92.1	1.55	2.31	50	G60 min
400 MST 250 - 54				4	102	1.62	2.42		
600 MST 250 - 54				6	152	2.02	3.00		
800 MST 250 - 54				8	203	2.41	3.58		
362 MST 250 - 68	68 Orange	0.0713	1.81	3-5/8	92.1	1.95	2.90	50	G60 min
400 MST 250 - 68				4	102	2.04	3.03		
600 MST 250 - 68				6	152	2.53	3.77		
800 MST 250 - 68				8	203	3.02	4.50		

362: Member depth in 1/100ths inches. Thus 362 means 362/100 = 3.62"

250: Member leg total length in 1/100ths inches. Thus 250 means 250/100 = 2.5"

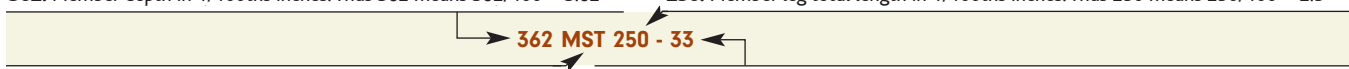

MST: Multi-Slot Track

33: Minimum thickness in 1/1000ths inches. Thus 33 means 33/1000 = 0.033"

* Weight is based on design steel thickness of net section. ** Meets ASTM A1003: Specification for Steel Sheet, Carbon, Metallic and Nonmetallic-Coated for Cold-Formed Framing Members. *** Meets ASTM A653: Specification for Steel Sheet, Zinc-Coated (Galvanized) or Zinc Iron Alloy-Coated (Galvannealed) by the Hot-Dip Process.

MULTI-SLOT TRACK MST 250

INSTALLATION

Connect the Multi-Slot MST 250 Track to the steel framing studs with #10 wafer or hex head screws. Install fasteners at the proper locations. Details for some common applications are provided on the following page.

MATERIAL SPECIFICATIONS

Bailey Multi-Slot Track is available in the following material specifications:

18 Mils, design thickness 0.0188 in. (0.478 mm)
 33 Mils, design thickness 0.0346 in. (0.879 mm)
 43 Mils, design thickness 0.0451 in. (1.15 mm)
 33 ksi Yield Stress

54 Mils, design thickness 0.0566 in. (1.44 mm)
 68 Mils, design thickness 0.0713 in. (1.81 mm)
 50 ksi Yield Stress

Coating designation G40, G60 or G90 is hot dipped galvanized, complying with ASTM A653 or equivalent.

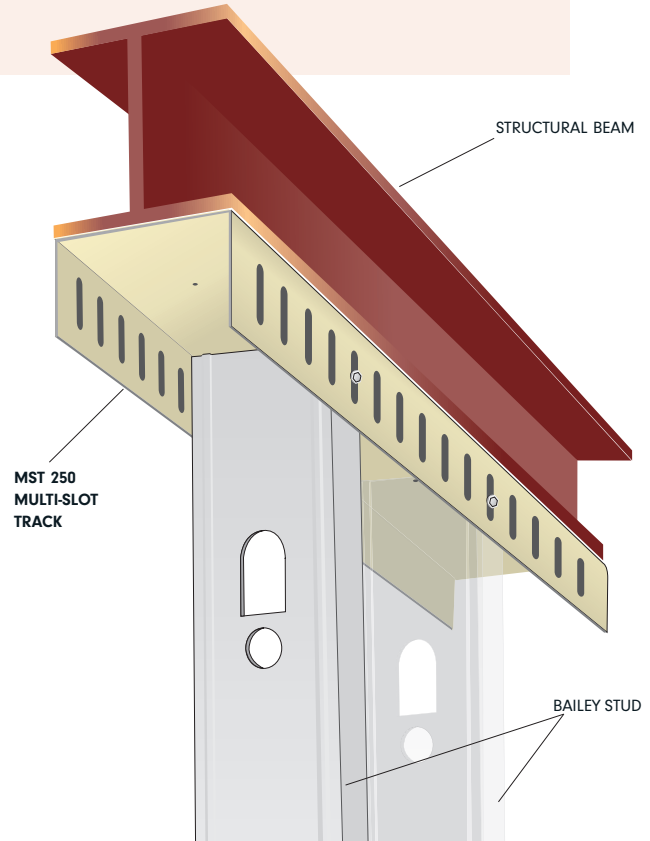

BAILEY MST 250 TRACK LOAD CAPACITIES

MST 250 Track			Service Limit Load at 1/8"	Service Limit Load at 3.18 mm	Ultimate Test Load	Ultimate Test Load	Resistance Factor	Factored Load Resistance	Factored Load Resistance
Mils	Yield Stress		P _{sll} (lb)	P _{sll} (kN)	P _{ut} (lb)	P _{ut} (kN)	φ	P _r (lb)	P _r (kN)
	(ksi)	(MPa)							
33	33	230	189	0.841	389	1.73	0.45	175	0.779
43	33	230	253	1.13	513	2.28	0.50	257	1.14
54	50	345	396	1.76	954	4.24	0.48	458	2.04
68	50	345	581	2.58	1267	5.64	0.48	608	2.71

TABLE NOTES:

- φ = Calibrated resistance factor based on test results.
- P_r = Factored load resistance = φ(P_{ut}).
- Track capacity loads were obtained from tests performed under the supervision of Dr. R. M. Schuster, P. Eng.
- The service limit load was recorded at 1/8" deflection according to the Research Note published by the LGSEA on CFS "Testing and Establishing Design Values for Clips" by Dr. Roger LaBoube, P.E., February 2002.
- Above loads are based on using #10 screws and following the installation instructions and standard details.
- Anchoring of the top track is the responsibility of the engineer of record.
- In the case where the stud thickness is less than the track thickness, web crippling must be checked in the stud by the engineer of record.

MULTI-SLOT TRACK MST 250

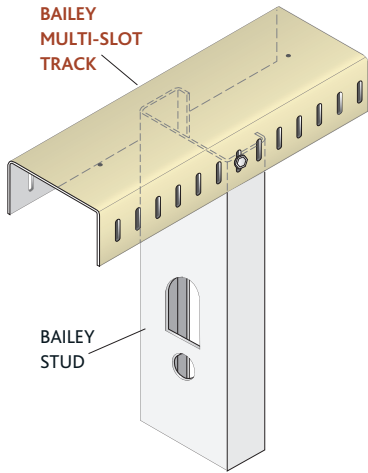

1.

Typical Installation of a single stud for standard spacing and uniform loading. Allow 0.75" clearance from top of the stud to the track and affix screws in the centre of each slot.

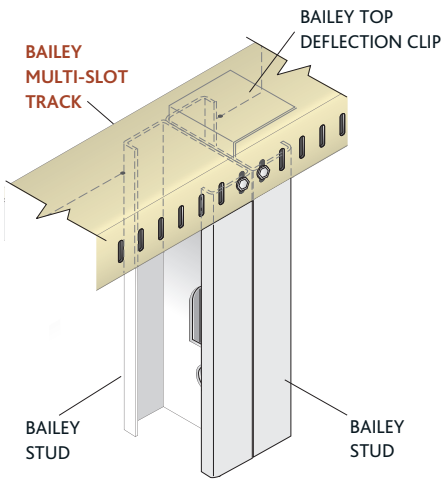
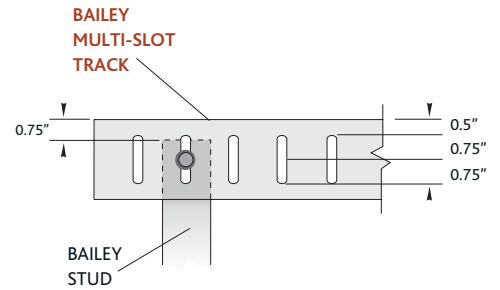

2.

For a non-uniform loads (window jambs, door jambs, etc) use the **Bailey Top Deflection Clip** sized to accommodate the extra load and increase the capacity of the MST 250.

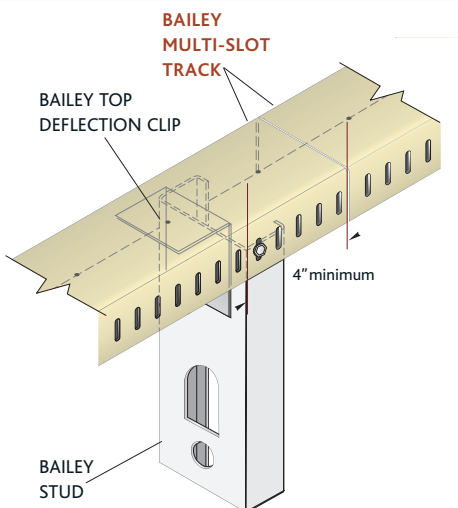
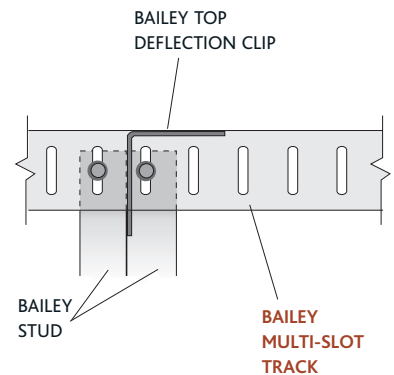

3.

Use the **Bailey Top Deflection Clip** to increase the capacity of the MST 250 whenever studs are placed within 4" from the ends of spliced track.

