



# BXUV.D504 - FIRE-RESISTANCE RATINGS - ANSI/UL 263

## Design/System/Construction/Assembly Usage Disclaimer

- Authorities Having Jurisdiction should be consulted in all cases as to the particular requirements covering the installation and use of UL Certified products, equipment, system, devices, and materials.
- Authorities Having Jurisdiction should be consulted before construction.
- Fire resistance assemblies and products are developed by the design submitter and have been investigated by UL for compliance with applicable requirements. The published information cannot always address every construction nuance encountered in the field.
- When field issues arise, it is recommended the first contact for assistance be the technical service staff provided by the product manufacturer noted for the design. Users of fire resistance assemblies are advised to consult the general Guide Information for each product category and each group of assemblies. The Guide Information includes specifics concerning alternate materials and alternate methods of construction.
- Only products which bear UL's Mark are considered Certified.

BXUV - Fire Resistance Ratings - ANSI/UL 263 Certified for  
United States

BXUV7 - Fire Resistance Ratings - CAN/ULC-S101 Certified for  
Canada

See General Information for Fire-resistance Ratings - ANSI/UL 263 Certified for United States  
Design Criteria and Allowable Variances

See General Information for Fire Resistance Ratings - CAN/ULC-S101 Certified for Canada  
Design Criteria and Allowable Variances

## **Design No. D504**

April 05, 2019

### **Restrained Assembly Rating — 2 Hr**

**Unrestrained Assembly Ratings — 1-1/2 Hr or 2 Hr (See Item 4)**

**Loading Determined by Allowable Stress Design Method**

**or Load and Resistance Factor Design Method**

**published by the American Institute of Steel Construction,**

**or in accordance with the relevant Limit State Design provisions**

**of Part 4 of the National Building Code of Canada.**

**\* Indicates such products shall bear the UL or cUL Certification Mark for jurisdictions employing the UL or cUL Certification (such as Canada), respectively.**

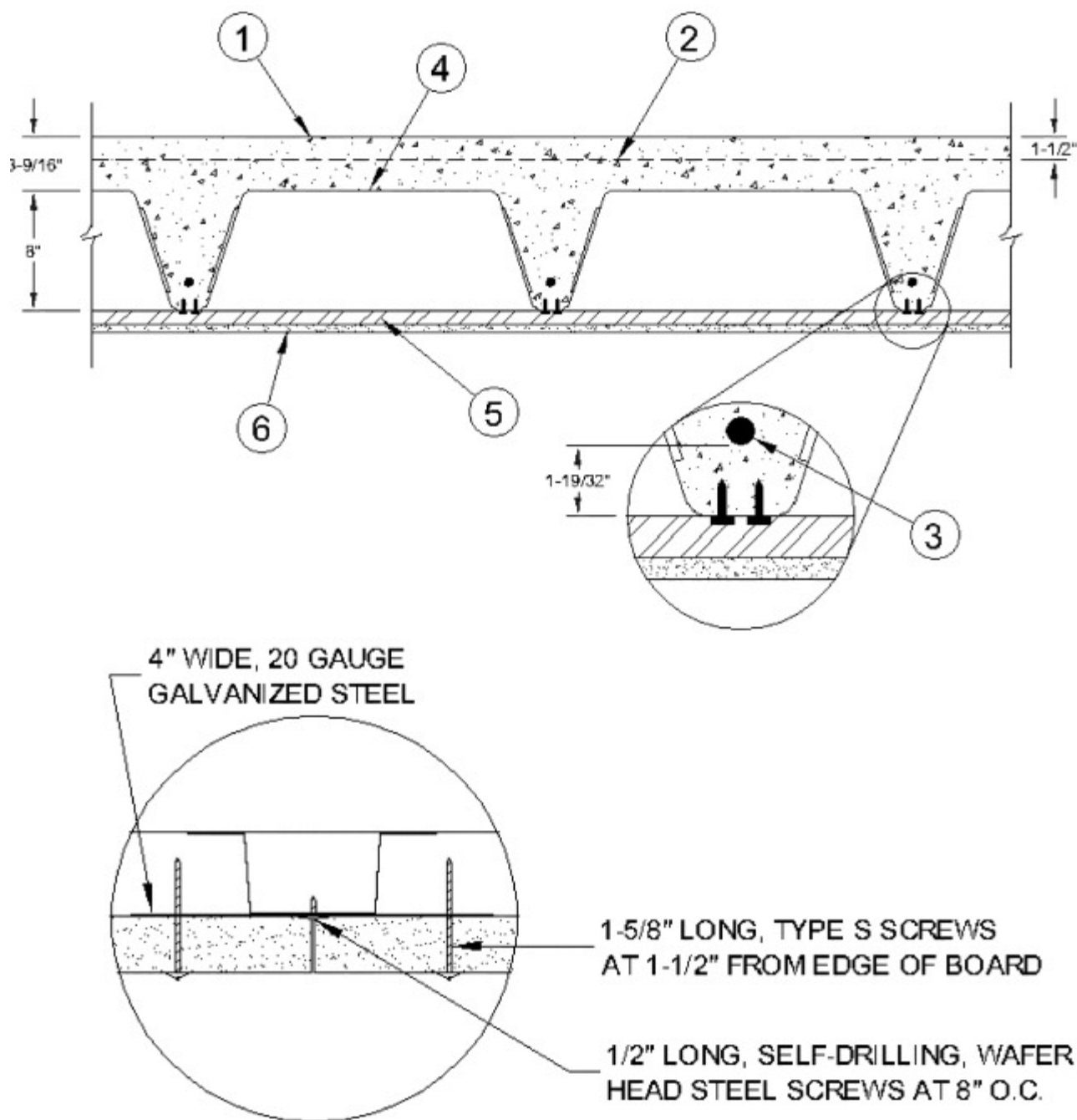

## BUTT-END JOINT DETAIL

1. **Normal-Weight Concrete** — Normal weight concrete, carbonate or siliceous aggregate, 150 ( $\pm$  3) pcf unit weight, 4350 psi compressive strength: Min concrete topping thickness 3-9/16 in. measured from the crest of the floor units.

2. **Welded-Wire Fabric** — 6 X 6 - Min wire thickness W2.9 X W2.9.

3. **Rib — Reinforcement** — Steel reinforcement designed in accordance with ACI 318 latest edition and deck manufacturer's load tables. Min concrete cover below the steel reinforcement shall be 1-19/32 in.

4. **Steel Floor and Form Units\*** — Composite, nom 8 in. deep galv steel units. Min 20 MSG. Side joints of adjacent units fully overlapped, fastened together by using 1-1/4 in. long self-drilling, self-tapping steel screws driven through Shear-Bond Clips (not shown) at 13-3/4 in. OC. Steel end closures flashings (not shown) made of min gauge 16 MSG galv. Shoring of the units during construction as per manufacturer's instructions. End connection to fire

rated supports as per manufacturer's instructions. Loading of the units to be in accordance with manufacturer's load tables based on simply supported conditions. For unit clear span of 32 ft, 9-5/8 in or less the Unrestrained Assembly Rating is 2 hr; for span greater than 32 ft, 9-5/8 in. the Unrestrained Assembly Rating is 1-1/2 h. "Please consult the below-listed deck manufacturer for comprehensive load tables and design parameters associated with this assembly."

**BAILEY METAL PRODUCTS LTD** — Type COMSLAB™ 210 and COMSLAB™ 225

5. **Furring Channels** — Min 25 MSG galv steel top hat sections, nom 7/8 in. deep, 2-3/4 in. overall width with 1/2 in. brim, spaced at 16 in. OC running perpendicular to the deck flutes. Channels fixed to underside of deck flutes, prior to concrete placement, with No.10, 3/4 in. long, wafer head, self-drilling screws. Channels shall be fixed to the steel floor units at each flute with 2 screws, one on each brim of the channel and staggered by min 1/4 in. from the opposite side.

6. **Gypsum Wallboard\*** — One layer of 5/8 in. thick, 4 ft wide wallboard. Wallboard installed with long dimensions perpendicular to furring channels and fastened to every channel with 1-1/4 in. long Type S, bugle-head steel screws spaced at max 11-3/4 in. OC. Screws along the long edges of the boards shall be located 1-1/2 in. from the edges of the boards. Each butt end joint shall be centered on a furring channel and backed, for the length of the butt end joint and for a distance of 3 in. beyond the joint in both directions, with a continuous 4 in. wide strip of min 20 MSG galv sheet steel. The sheet steel strip shall be fixed, prior to the attachment of the wallboard, to the furring channel with No. 8, 1/2 in. long, self-drilling, wafer head steel screws spaced at 8 in. OC. The butt ends shall be attached to the sheet steel backing using 1-5/8 in. long Type S, bugle-head steel screws located 1-1/2 in. from the butt end edges and spaced at max 11-3/4 in. OC. The butt end joints in adjacent boards shall be staggered by 4 ft. All joints shall be covered with paper tape and 2 coats of joint compound. Paper tape shall be embedded in the first layer of the joint compound. All screw heads shall be covered with 2 coats of joint compound.

**CERTAINTED GYPSUM INC** — Type C

**THAI GYPSUM PRODUCTS PCL** — Type C

**UNITED STATES GYPSUM CO** — Type C, ULIX

**USG BORAL DRYWALL SFZ LLC** — Type C

**\* Indicates such products shall bear the UL or cUL Certification Mark for jurisdictions employing the UL or cUL Certification (such as Canada), respectively.**

Last Updated on 2019-04-05

---

The appearance of a company's name or product in this database does not in itself assure that products so identified have been manufactured under UL's Follow-Up Service. Only those products bearing the UL Mark should be considered to be Certified and covered under UL's Follow-Up Service. Always look for the Mark on the product.

UL permits the reproduction of the material contained in the Online Certification Directory subject to the following conditions: 1. The Guide Information, Assemblies, Constructions, Designs, Systems, and/or Certifications (files) must be presented in their entirety and in a non-misleading manner, without any manipulation of the data (or drawings). 2. The statement "Reprinted from the Online Certifications Directory with permission from UL" must appear adjacent to the extracted material. In addition, the reprinted material must include a copyright notice in the following format: "© 2019 UL LLC"