

# A GUIDE TO FIRE & ACOUSTIC DATA FOR STEEL FLOOR, WALL & ROOF ASSEMBLIES

(August 2009)

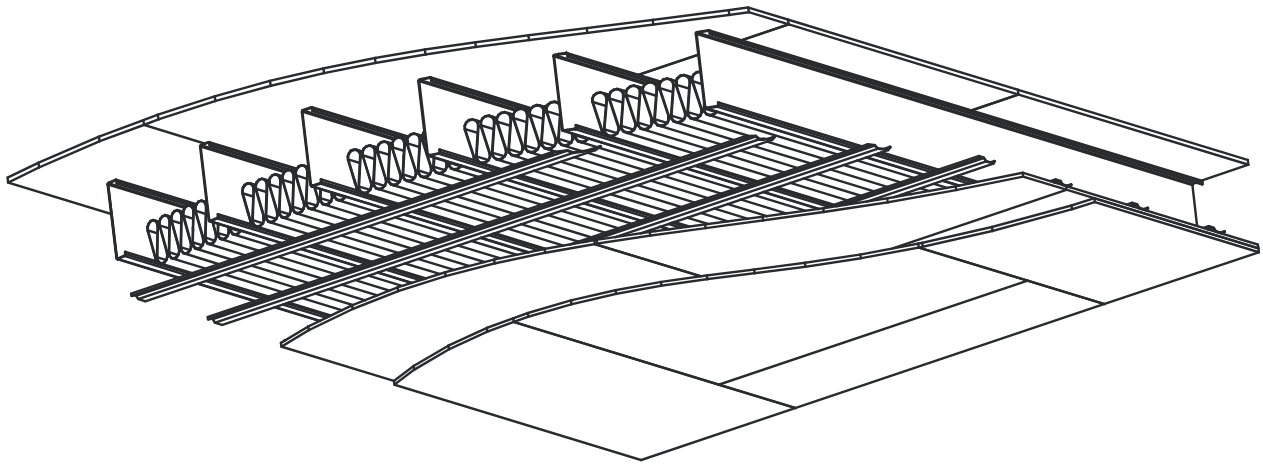

Supported By:



## DISCLAIMER

The material in this guide has been prepared as a reference of fire and sound rated lightweight steel framed assemblies. While every effort has been taken to ensure that the material is technically correct, it only offers a brief description of the tested assemblies. It must not be used without first reviewing the source documents of the testing agencies for a full description of the assembly. The Steel Framing Alliance, nor their organization's members, warrant or assume liability for the suitability of the material for any general or particular use.

Please note that some assemblies are constructed with proprietary products that may not be available in all geographical areas. Please consult the source documents of the testing agencies for these details. Where fire rated designs utilize a proprietary steel joist, fluted unit, light gauge steel truss or steel stud, the source column appears shaded and the word proprietary is in bold font to allow ease of identification for an assembly built with a proprietary cold formed steel product.

Steel Framing Alliance  
1201 15<sup>th</sup> Street, N.W., Suite 320  
Washington, D.C., U.S.A., 20005  
Tel: (202) 785-2022  
[www.steel framing.org](http://www.steel framing.org)

## PREFACE

The purpose of this guide is to amalgamate fire and sound data for steel floor, wall and roof assemblies that are relevant to residential and light commercial construction. Fire data has been compiled from the following six sources:

Underwriters' Laboratories of Canada    ULC  
7 Underwriters Road  
Toronto, Ontario, Canada M1R 3B4  
[www.ulc.ca](http://www.ulc.ca)

National Research Council of Canada    NRCC  
Institute for Research in Construction  
1200 Montreal Road  
Ottawa, Ontario, Canada K1A OR6  
[www.irc.nrc-cnrc.gc.ca](http://www.irc.nrc-cnrc.gc.ca)

Underwriters Laboratories Inc.            UL  
333 Pfingsten Road  
Northbrook, Illinois, U.S.A. 60062-2096  
[www.ul.com](http://www.ul.com)

Gypsum Association                        GA  
6525 Belcrest Rd.  
Suite 480  
Hyattsville, Maryland, U.S.A. 20782  
[www.gypsum.org](http://www.gypsum.org)

Factory Mutual Global Research            FM  
FM Global Corporate Offices  
1301 Atwood Ave.  
PO Box 7500  
Johnston, Rhode Island, U.S.A. 02919  
[www.fmglobal.com](http://www.fmglobal.com)

Intertek Group plc                         Intertek  
25 Savile Row  
London, United Kingdom W1S 2ES  
[www.spec-direct.com](http://www.spec-direct.com)

## NOTES

1. ULC Design Numbers (published in the Fire Resistance Directory of Underwriters' Laboratories of Canada) and NRCC Report/Assembly Numbers (research publications of the Institute for Research in Construction, National Research Council of Canada) should be referenced when considering steel floor, wall and roof assembly designs in Canadian Building Code jurisdictions.
2. For non-load bearing wall assemblies, steel stud thickness as per ASTM C 645, Standard Specification for Nonstructural Steel Framing Members, where minimum thickness is specified as 0.0179 in. (0.455 mm) before application of protective coating or in conformance with Section 9.
3. The majority of sound data that has been incorporated into this guide were based on the following report:

Warnock, A.C.C., *Estimation of Sound Transmission Class and Impact Insulation Class Rating for Steel Framed Assemblies*, Report No. B3436.1 Revised, Institute for Research in Construction, National Research Council of Canada, Ottawa, Ontario, Canada, December 2008.

The above report has surveyed existing published sound test reports denoted in the source column by an alphanumeric acoustic test identifier. Letter prefixes in the identifier denote various acoustic testing laboratories. The report also provides numerous acoustic "estimates" and these have been noted with an asterisk that refers to the above report, i.e., Warnock (2008). The report is available as a Steel Framing Alliance Research Report (RP08-7) from their website (<http://store.steel framingalliancestore.com/esofsotrclan.html>) as a free download in the form of an Adobe Acrobat file. Acoustic estimates were made with an acoustic "SOund Classification RAting ESTimator" called "Socrates" that is available from the National Research Council of Canada via the following website:

[http://irc.nrc-cnrc.gc.ca/ie/floors/socrates\\_e.html](http://irc.nrc-cnrc.gc.ca/ie/floors/socrates_e.html)

Further information on "Socrates" is also available via the following website:

<http://www.alfwarnock.info/sound/socindex.html>

Acoustic data in some cases appears with the following codes to denote a material:

AIR – a gap in the construction (a layer of air with thickness)

CAR-UND – carpet and underpad

CEMBRD – cement board (with thickness)

## NOTES (continued)

G – gypsum board (with thickness)  
GFB – glass fiber batts (with thickness)  
NI – no insulation  
NRC – no resilient metal channels  
RC - resilient metal channels  
RFB – rock fiber (mineral wool) batts (with thickness)

4. Information on UL fire rated cold-formed steel truss assemblies is available from the Cold-Formed Steel Council via the following webpage:

[http://www.cfsc.sbcindustry.com/docs/Fire\\_Assemblies\\_SSC.pdf](http://www.cfsc.sbcindustry.com/docs/Fire_Assemblies_SSC.pdf)

5. Details of UL and ULC listings for fire rated floor, wall and truss assemblies can be downloaded from the website of UL and ULC by using the alphanumeric fire identifier within a keyword search. For example, on the UL website enter the following information:

- go to UL website at: <http://www.ul.com>
- click on “Certifications” located along left side of webpage
- type in alphanumeric fire identifier, for example “L568” in keyword box and click on “Search”
- go to row with “Design No. L568” and click on “[BXUV.L568](#)”

Similarly for the ULC website enter the following information:

- go to ULC website at: <http://www.ulc.ca>
- click on “Online Directories” located along top of webpage
- on the “Online Directories” webpage, click on “ULC Online Directories”
- in “Keyword” type in alphanumeric fire identifier, for example “M511” in keyword box and click on “Search”
- go to row with “Design No. M511” and click on “[BXUVC.M511](#)”

6. UL Floor and Load Bearing Wall Designs using cold-formed steel joists and studs can be used for Canadian application without a Load Restriction, i.e., a “Load Restricted Factor” equal to 1.00. Details regarding this restricted load use condition have been added to “*BXUV7.GuideInfo, Fire Resistance Ratings - CAN/ULC-S101 Certified for Canada*”. The percent load reductions in Table 1 of “*BXUV7.GuideInfo*” for typical assemblies are based upon loading calculated in accordance with the working stress design method as compared to loading calculated in accordance with the limit states design method. The fire resistance ratings for floors supported by cold-formed steel channels and walls supported by cold-formed steel studs do not have a Load Restriction Factor because the

## NOTES (continued)

associated loads in Canada and the U.S. are based on the same standard: CSA S136-07, “North American Specification for the Design of Cold-Formed Steel Structural Members”, and ANSI/AISI S100-07, “North American Specification and Commentary for the Design of Cold-Formed Steel Structural Members”.

7. As per UL’s “*BXUV.GuideInfo, Fire Resistance Ratings – ANSI/UL 263*” and ULC’s “*BXUVC GuideInfo, Fire Resistance Ratings (Guide No. 40 U18)*” the dimensions and thickness (gauge) of steel studs and joists are minimums. The hourly ratings apply when the steel studs and joists are larger in thickness (heavier gauge) and/or have larger dimensions than specified in a design, or when the member spacing is less than what was tested.
8. UL non-load bearing wall and load bearing wall assemblies provide stud material thickness with a Manufacturers’ Standard Gauge (MSG) number. UL’s “*BXUV.GuideInfo, Fire Resistance Ratings – ANSI/UL 263*” provides the following thickness tables where an MSG is stated in the fire rated design.

For load-bearing steel studs:

MSG	Minimum bare metal thickness (in.)
20	0.0329
18	0.0428
16	0.0538
14	0.0677

For non-load bearing steel studs:

MSG	Minimum bare metal thickness (in.)
25	0.018
24	0.021
22	0.027
20	0.033
18	0.044
16	0.055

## **ACKNOWLEDGEMENTS**

The Steel Framing Alliance acknowledges Bill Kraft of the Steel Framing Alliance and George Frater of the Canadian Steel Construction Council as the Primary Authors of the first edition of this guide, which was published in 2004.

The Steel Framing Alliance is grateful to George Frater of the Canadian Steel Construction Council for his ongoing effort to keep this guide current and to serve as Primary Author of each of the updated editions, which were published in 2005, 2006, 2007 and 2009.

The Steel Framing Alliance also appreciates the guidance and feedback provided to the Primary Author by the members of the Fire and Acoustic Task Group of the Cold-Formed Steel Engineers Institute.

Acknowledgement is also made for the financial support provided by the Steel Stud Manufacturers Association for the NRCC Phase II joint research project on the Fire and Acoustical Performance of Floor Assemblies.

# TABLE OF CONTENTS

<b>DISCLAIMER</b> .....	ii
<b>PREFACE</b> .....	iii
<b>NOTES</b> .....	iv
<b>ACKNOWLEDGEMENTS</b> .....	vii
<b>FLOOR/CEILING ASSEMBLIES</b> .....	1
Underwriters' Laboratories of Canada.....	2
National Research Council of Canada .....	8
Underwriters Laboratories Inc .....	15
Gypsum Association .....	35
Factory Mutual Research .....	36
<b>NON-LOAD BEARING WALL ASSEMBLIES</b> .....	38
Underwriters' Laboratories of Canada.....	39
National Research Council of Canada .....	54
Underwriters Laboratories Inc. ....	55
Gypsum Association .....	77
Factory Mutual Research .....	80
Intertek Group plc.....	81
<b>LOAD BEARING WALL ASSEMBLIES</b> .....	83
Underwriters' Laboratories of Canada.....	84
National Research Council of Canada .....	87
Underwriters Laboratories Inc. ....	90
Gypsum Association .....	99
<b>ROOF/CEILING ASSEMBLIES</b> .....	100
Underwriters' Laboratories of Canada.....	101
Underwriters Laboratories Inc. ....	102



# **FLOOR/CEILING ASSEMBLIES**

## Floor/Ceiling - Underwriters' Laboratories of Canada

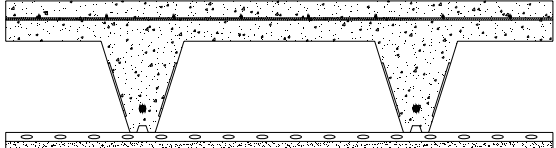
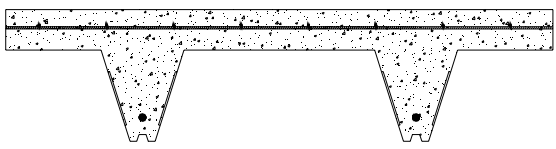
Source	Description	Fire Resistance Rating	Sound Transmission Class	Impact Insulation Class	
<b>ULC D500</b>  K.E. Barron, P.Eng. 98-02-10 report available from Bailey Metal Products Ltd.	<ul style="list-style-type: none"> <li>min. 90 mm concrete topping</li> <li>152 mm by 152 mm MW18.7/MW18.7 welded steel wire mesh</li> <li>steel reinforcing bar with 40 mm concrete cover</li> <li>composite galvanized fluted units, <b>proprietary</b> COMFLOR® 210, 203 mm deep or SLIMDEK® 225, 225 mm deep with a min. design thickness of 0.96 mm by Bailey Metal Products Ltd.</li> <li>furring channels spaced 406 mm o.c.</li> <li>1 layer of 15.9 mm gypsum board on ceiling side</li> </ul> <p>* for steel deck span &gt; 10 m                      ** for steel deck span ≤ 10m                      *** Field obtained STC</p>		1-½ h *	57***	
			2 h **		
<b>ULC F909</b>  K.E. Barron, P.Eng. 98-02-10 report available from Bailey Metal Products Ltd.	<ul style="list-style-type: none"> <li>64 mm concrete topping for 1 h and 90 mm for 1½ h</li> <li>152 mm by 152 mm MW18.7/MW18.7 welded steel wire mesh</li> <li>steel reinforcing bar with 40 mm concrete cover</li> <li>composite galvanized fluted units, <b>proprietary</b> COMFLOR® 210, 203 mm deep or SLIMDEK® 225, 225 mm deep with a min. design thickness of 0.9 mm by Bailey Metal Products Ltd.</li> </ul> <p>* for steel deck span ≤ 10m                      ** Field obtained STC</p>		1 h *	55**	
			1-½ h *		

## Floor/Ceiling - Underwriters' Laboratories of Canada

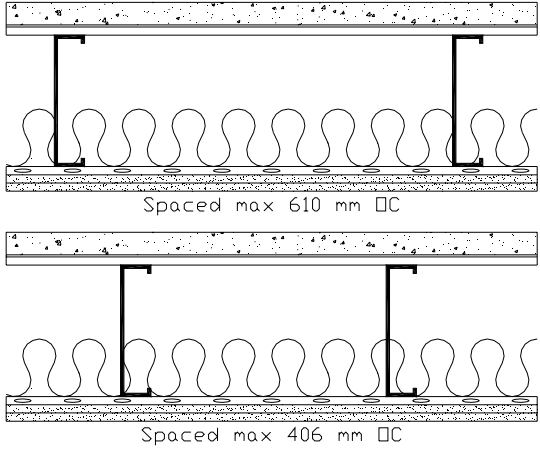
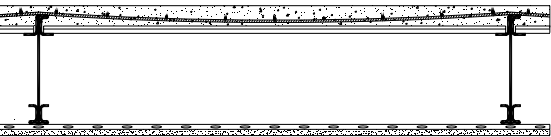
Source	Description	Fire Resistance Rating	Sound Transmission Class	Impact Insulation Class
<b>ULC I523</b> a) TLF-02-051a b) IIF-02-032	<ul style="list-style-type: none"> <li>35 mm concrete</li> <li>0.38 mm thick steel deck with 15.9 mm deep corrugations</li> <li>203 mm deep steel joist with 1.15 mm material thickness and spaced at 406 mm o.c. or 610 mm o.c.</li> <li>optional resilient metal channels spaced 610 mm o.c.</li> <li>optional 90 mm mineral wool or glass fibre batt insulation</li> <li>2 layers of 12.7 mm gypsum board on ceiling side</li> </ul>			
		1 h	610 mm joist spacing	
			65* (GFB RC) 60* (NI RC)	29* (GFB RC) 30* (NI RC)
			406 mm joist spacing	
66 <sup>a</sup> (GFB RC) 60* (NI RC)	34 <sup>b</sup> (GFB RC) <30* (NI RC)			
<b>ULC I525</b>	<ul style="list-style-type: none"> <li>70 mm concrete slab with 150 mm by 150 mm MW13.3/MW13.3 welded wire fabric on 0.76 mm thick steel deck with 22 mm deep corrugations</li> <li>280 mm deep <b>proprietary</b> composite steel joist, iSPAN™ licensed by Genesis TP in USA and Canada, with 1.47 mm material thickness and spaced at 1219 mm o.c.</li> <li>furring channels spaced 400 mm o.c.</li> <li>1 layer of 15.9 mm gypsum board on ceiling side</li> </ul>			
		2 h	50 (70 mm slab) 53 (108 mm slab)	25 (70 mm slab) 34 (108 mm slab)

\* Estimated value as per Warnock (2008)

## Floor/Ceiling - Underwriters' Laboratories of Canada

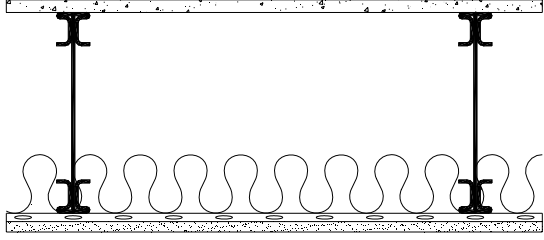
Source	Description	Fire Resistance Rating	Sound Transmission Class	Impact Insulation Class	
ULC 1526	<ul style="list-style-type: none"> <li>subfloor of 19 mm thick tongue-and-groove cement-fibre board designated "Fortacrete"</li> <li>300 mm deep <b>proprietary</b> steel joist, iSPAN™ licensed by Genesis TP in USA and Canada, with 1.2 mm material thickness and spaced at 600 mm o.c.</li> <li>resilient metal channels spaced 300 mm o.c.</li> <li>92 mm thick glass-fibre batt insulation</li> <li>1 layer of 15.9 mm gypsum board on ceiling side</li> </ul>		1 h	56*	*
ULC 1527	<ul style="list-style-type: none"> <li>subfloor of 19 mm thick tongue-and-groove cement-fibre board designated "Fortacrete" topped with 12.7 mm thick gypsum board (System A) or 19 mm thick floor topping mixture (System B)</li> <li>300 mm deep <b>proprietary</b> steel joist, iSPAN™ licensed by Genesis TP in USA and Canada, with 1.2 mm material thickness and spaced at 600 mm o.c.</li> <li>resilient metal channels spaced 300 mm o.c.</li> <li>92 mm thick glass-fibre batt insulation</li> <li>2 layers of 15.9 mm gypsum board on ceiling side</li> </ul>				

\* Brunette, N.L., Airborne Sound Transmission Loss and Impact Sound Transmission Measurements Performed on One Floor Assembly, NRC Client Report B-3454.1, National Research Council of Canada, Ottawa, Ontario, Canada, 2007.

\*\* Brunette, N.L., Airborne Sound Transmission Loss and Impact Sound Transmission Measurements Performed on One Floor Assembly, NRC Client Report B-3454.6, National Research Council of Canada, Ottawa, Ontario, Canada, 2007.

## Floor/Ceiling - Underwriters' Laboratories of Canada

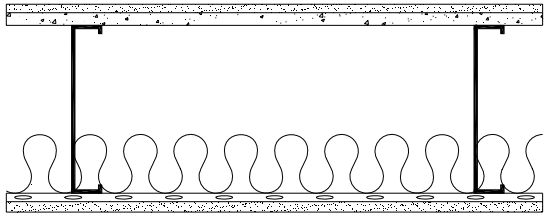
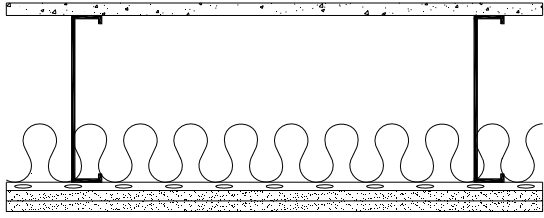
Source	Description	Fire Resistance Rating	Sound Transmission Class	Impact Insulation Class
ULC I528	<ul style="list-style-type: none"> <li>• 1-½ hours - subfloor of 19 mm thick tongue-and-groove cement-fibre board designated "Fortacrete"</li> <li>• 2 hours - subfloor of 19 mm thick tongue-and-groove cement-fibre board designated "Fortacrete" topped with 12.7 mm thick gypsum board (System A) or 19 mm thick floor topping mixture (System B)</li> <li>• 254 mm deep with 1.6 mm material thickness and spaced at 610 mm o.c.</li> <li>• resilient metal channels spaced 305 mm o.c.</li> <li>• 92 mm thick glass-fibre batt insulation</li> <li>• 1 layer of 15.9 mm gypsum board on ceiling side</li> </ul> <p>* 96% load restriction</p>		<p>* 1-½ h * 2 h</p>	<p>-</p>
ULC I529	<ul style="list-style-type: none"> <li>• subfloor of 19 mm thick tongue-and-groove cement-fibre board designated "Fortacrete"</li> <li>• 254 mm deep with 1.6 mm material thickness and spaced at 610 mm o.c.</li> <li>• resilient metal channels spaced 305 mm o.c.</li> <li>• 92 mm thick glass-fibre batt insulation</li> <li>• 2 layers of 15.9 mm gypsum board on ceiling side</li> </ul> <p>* 96% load restriction</p>		<p>* 2 h</p>	<p>-</p>

## Floor/Ceiling - Underwriters' Laboratories of Canada

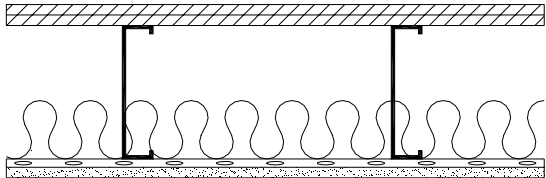
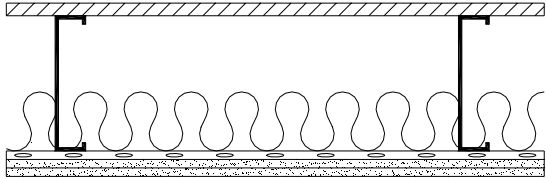
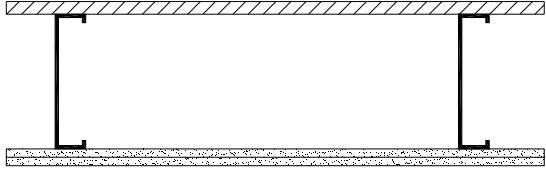
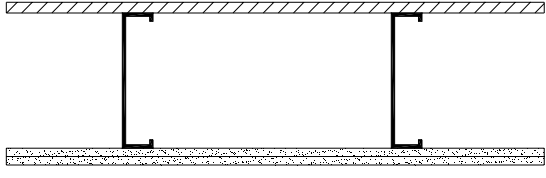
Source	Description	Fire Resistance Rating	Sound Transmission Class	Impact Insulation Class	
ULC M511	<ul style="list-style-type: none"> <li>subfloor of 15.9 mm plywood and finish floor of 15.9 mm wood structural panels</li> <li>203 mm deep steel joist with 1.15 mm material thickness and spaced at 406 mm o.c.</li> <li>resilient metal channels spaced 406 mm o.c.</li> <li>90 mm thick mineral wool batt insulation</li> <li>1 layer of 15.9 mm gypsum board on ceiling side</li> </ul>		45 min	53*	46*
	<ul style="list-style-type: none"> <li>subfloor of 19 mm plywood</li> <li>203 mm deep steel joist with 1.15 mm material thickness and spaced at 610 mm o.c.</li> <li>resilient metal channels spaced 406 mm o.c.</li> <li>90 mm thick glass fibre batt insulation</li> <li>2 layers of 12.7 mm gypsum board on ceiling side</li> </ul>		45 min	52*	45*
	<ul style="list-style-type: none"> <li>subfloor of 19 mm plywood</li> <li>203 mm deep steel joist with 1.15 mm material thickness and spaced at 610 mm o.c.</li> <li>2 layers of 12.7 mm gypsum board on ceiling side</li> </ul>		45 min	<40*	<40*
	<ul style="list-style-type: none"> <li>subfloor of 15.9 mm plywood</li> <li>203 mm deep steel joist with 1.15 mm material thickness and spaced at 406 mm o.c.</li> <li>2 layers of 12.7 mm gypsum board on ceiling side</li> </ul>		1 h	<40*	<40*

\* Estimated value as per Warnock (2008)

# Floor/Ceiling - Underwriters' Laboratories of Canada

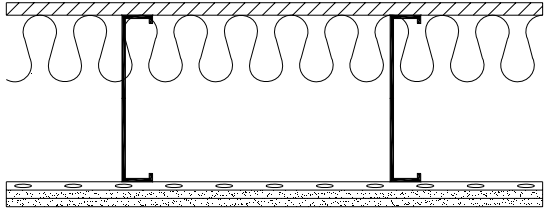
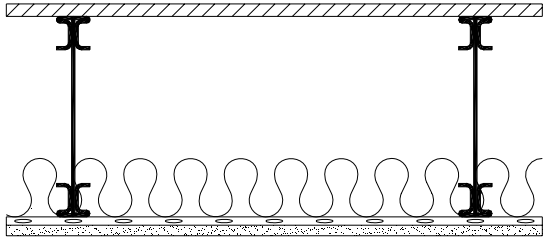
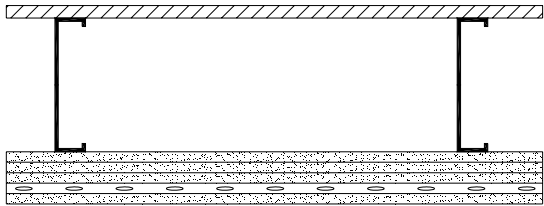
Source	Description	Fire Resistance Rating	Sound Transmission Class	Impact Insulation Class
ULC M512	<ul style="list-style-type: none"> <li>subfloor of 19 mm plywood</li> <li>250 mm deep 16 MSG <b>proprietary</b> steel joist (Rotary Press Systems Inc.) spaced at 400 mm o.c.</li> <li>resilient metal channels spaced 400 mm o.c.</li> <li>100 mm thick mineral wool insulation</li> <li>2 layers of 12.7 mm gypsum board on ceiling side</li> </ul> <p>* 79% of load restriction</p>			
		* 1 h	-	-
ULC M513	<ul style="list-style-type: none"> <li>subfloor of 19 mm plywood or OSB</li> <li>300 mm deep <b>proprietary</b> steel joist, iSPAN™ licensed by Genesis TP in USA and Canada, with 1.2 mm material thickness and spaced at 600 mm o.c.</li> <li>resilient metal channels spaced 300 mm o.c.</li> <li>75 mm thick mineral wool batt insulation</li> <li>1 layer of 16 mm gypsum board on ceiling side</li> </ul>			
		1 h	50	45
ULC M514 a) NGC5004021 b) NGC7004068 c) NGC7004069	<ul style="list-style-type: none"> <li>subfloor of 19 mm plywood</li> <li>203 mm deep steel joist with 1.07 mm material thickness and spaced at 610 mm o.c.</li> <li>4 layers of 15.9 mm Type X gypsum board on ceiling side</li> <li>resilient metal channels spaced 610 mm o.c. and applied perpendicular to joists over third layer of gypsum board</li> </ul>			
		2 h	48 <sup>a</sup>	37 <sup>b</sup> 60 <sup>c</sup> (CAR-UND)

## Floor/Ceiling – National Research Council of Canada

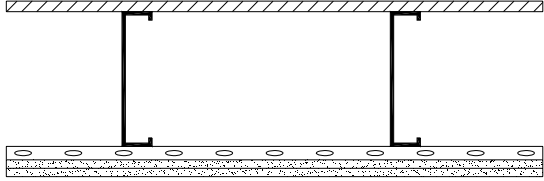
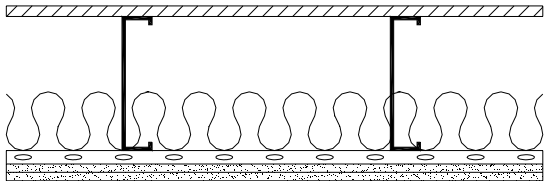
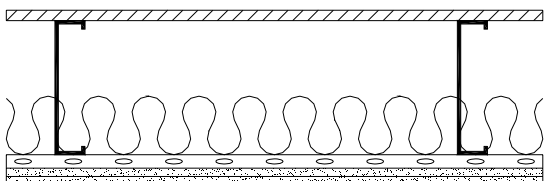
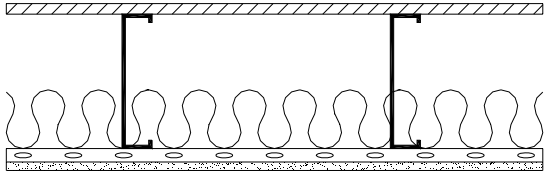
Source	Description	Fire Endurance	Sound Transmission Class	Impact Insulation Class	
NRCC IR-764 FF22	<ul style="list-style-type: none"> <li>subfloor of 15.9 mm plywood</li> <li>203 mm deep steel joist with 1.22 mm material thickness and spaced at 406 mm o.c.</li> <li>resilient metal channels spaced 406 mm o.c.</li> <li>2 layers of 12.7 mm Type X gypsum board on ceiling side</li> </ul>		74 min	<50*	<40* 60**
NRCC IR-764 FF23 a) TLF-01-003a b) TLF-01-005a c) IIF-00-036 d) IIF-01-001	<ul style="list-style-type: none"> <li>subfloor of 15.9 mm plywood</li> <li>203 mm deep steel joist with 1.22 mm material thickness and spaced at 406 mm o.c.</li> <li>resilient metal channels spaced 406 mm o.c.</li> <li>90 mm thick glass fibre insulation</li> <li>2 layers of 12.7 mm Type X gypsum board on ceiling side</li> </ul>		68 min	49 <sup>a</sup> 52 <sup>b</sup> (CAR-UND)	39 <sup>c</sup> 70 <sup>d</sup> (CAR-UND)
NRCC IR-764 FF24	<ul style="list-style-type: none"> <li>subfloor of 15.9 mm plywood</li> <li>203 mm deep steel joist with 1.22 mm material thickness and spaced at 610 mm o.c.</li> <li>resilient metal channels spaced 406 mm o.c.</li> <li>90 mm thick glass fibre insulation</li> <li>2 layers of 12.7 mm Type X gypsum board on ceiling side</li> </ul>		69 min	49*	42* 62**
NRCC IR-764 FF25	<ul style="list-style-type: none"> <li>subfloor of 15.9 mm plywood</li> <li>203 mm deep steel joist with 1.22 mm material thickness and spaced at 406 mm o.c.</li> <li>resilient metal channels spaced 406 mm o.c.</li> <li>90 mm thick mineral fibre insulation</li> <li>1 layer of 12.7 mm Type X gypsum board on ceiling side</li> </ul>		46 min	45*	39* 64**
* Estimated value as per Warnock (2008)		** With carpet and pad (Warnock, 2000)			

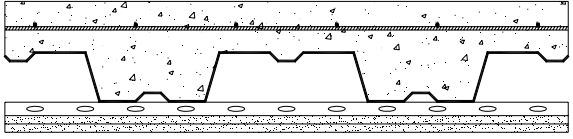
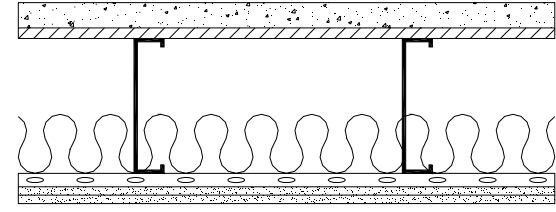

## Floor/Ceiling – National Research Council of Canada

Source	Description	Fire Endurance	Sound Transmission Class	Impact Insulation Class
NRCC IR-764 FF26 a) TLF-97-109a b) IIF-97-049	<ul style="list-style-type: none"> <li>76 mm composite concrete slab with 152 mm by 152 mm MW3.8/MW3.8 welded steel wire mesh on 0.91 mm thick steel deck with 76 mm deep corrugations</li> <li>resilient metal channels spaced 406 mm o.c.</li> <li>2 layers of 12.7 mm Type X gypsum board on ceiling side</li> </ul>			
		105 min	57 <sup>a</sup>	36 <sup>b</sup> 70 <sup>**</sup>
NRCC IR-764 FF27	<ul style="list-style-type: none"> <li>38 mm concrete topping</li> <li>subfloor of 15.9 mm plywood</li> <li>203 mm deep steel joist with 1.22 mm material thickness and spaced 406 mm o.c.</li> <li>resilient metal channels spaced 406 mm o.c.</li> <li>90 mm thick glass fibre insulation</li> <li>2 layers of 12.7 mm Type X gypsum board on ceiling side</li> </ul>			
		60 min	66*	36* 70 <sup>**</sup>
* Estimated value as per Warnock (2008)		** With carpet and pad (Warnock, 2000)		

### References:

Sultan, M.A., Séguin, Y.P. and Leroux, P., *Results of Fire Resistance Tests on Full-Scale Floor Assemblies*, IRC Internal Report No. 764, National Research Council of Canada, Ottawa, Ontario, Canada, May 1998.

Warnock, A.C.C. and Birta, J.A., *Summary Report for Consortium on Fire Resistance and Sound Insulation of Floors: Sound Transmission Class and Impact Insulation Class Results*, IRC Internal Report No. 766, National Research Council of Canada, Ottawa, Ontario, Canada, April 1998.

\*\* Warnock, A.C.C., *Sound Transmission Estimates for Steel-Framed Floor Assemblies*, Institute for Research in Construction, National Research Council of Canada, Ottawa, Ontario, Canada, January 12, 2000.

\* Warnock, A.C.C., *Estimation of Sound Transmission Class and Impact Insulation Class Rating for Steel Framed Assemblies*, Report No. B3436.1, Institute for Research in Construction, National Research Council of Canada, Ottawa, Ontario, Canada, December 2005.

Birta, J.A. and Warnock, A.C.C., *Airborne and Impact Sound Transmission Measurements Performed on Specimen B1363-1*, National Research Council of Canada, Ottawa, Ontario, Canada, 2001.

Birta, J.A. and Warnock, A.C.C., *Airborne and Impact Sound Transmission Measurements Performed on Specimen B1363-2*, National Research Council of Canada, Ottawa, Ontario, Canada, 2001.

## Floor/Ceiling – National Research Council of Canada

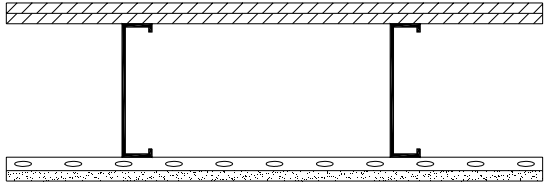
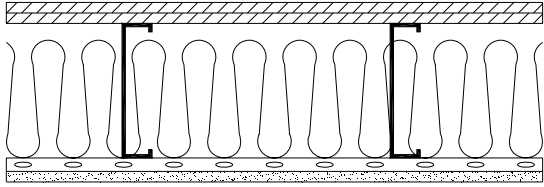
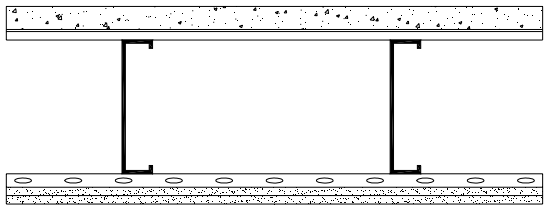
Source	Description	Fire Endurance	Sound Transmission Class	Impact Insulation Class
NRCC RR-184 FF37	<ul style="list-style-type: none"> <li>2 layers of 15.9 mm plywood subfloor</li> <li>203 mm deep steel joist with 1.22 mm material thickness and spaced at 406 mm o.c.</li> <li>resilient metal channels spaced 406 mm o.c.</li> <li>1 layer of 15.9 mm Type X gypsum board on ceiling side</li> </ul>			
		38 min	-	-
NRCC RR-184 FF38	<ul style="list-style-type: none"> <li>2 layers of 15.9 mm plywood subfloor</li> <li>203 mm deep steel joist with 1.22 mm material thickness and spaced at 406 mm o.c.</li> <li>resilient metal channels spaced 406 mm o.c.</li> <li>178 mm thick rock fibre insulation</li> <li>1 layer of 15.9 mm Type X gypsum board on ceiling side</li> </ul>			
		53 min	-	-
NRCC RR-184 FF40  a) TLF-03-011a b) IIF-03-005	<ul style="list-style-type: none"> <li>35 mm concrete</li> <li>0.38 mm thick steel deck with 15.9 mm deep corrugations</li> <li>203 mm deep steel joist with 1.22 mm material thickness and spaced at 406 mm o.c.</li> <li>resilient metal channels spaced 406 mm o.c.</li> <li>2 layers of 12.7 mm Type X gypsum board on ceiling side</li> </ul>			
		75 min	62 <sup>a</sup>	32 <sup>b</sup>

## Floor/Ceiling – National Research Council of Canada

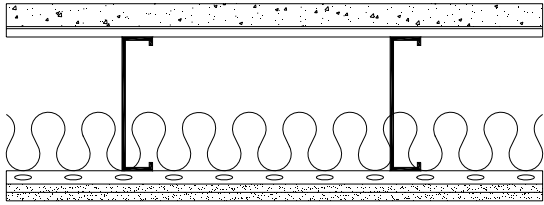
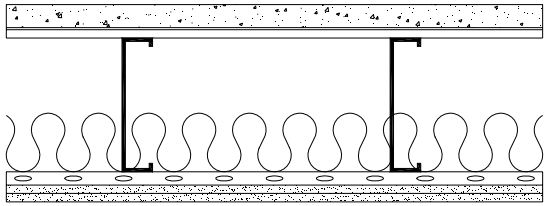
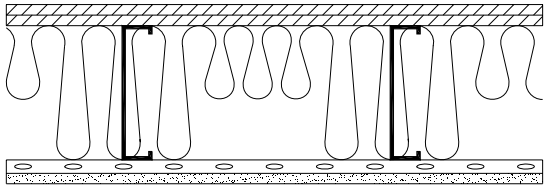
Source	Description	Fire Endurance	Sound Transmission Class	Impact Insulation Class
NRCC RR-184 FF43  a) TLF-03-005a b) IIF-03-003	<ul style="list-style-type: none"> <li>35 mm concrete</li> <li>0.38 mm thick steel deck with 15.9 mm deep corrugations</li> <li>203 mm deep steel joist with 1.22 mm material thickness and spaced at 406 mm o.c.</li> <li>resilient metal channels spaced 406 mm o.c.</li> <li>90 mm thick glass fibre insulation</li> <li>2 layers of 12.7 mm Type X gypsum board on ceiling side</li> </ul>			
		68 min	68 <sup>a</sup>	36 <sup>b</sup>
NRCC RR-184 FF44  a) TLF-02-051a b) IIF-02-032	<ul style="list-style-type: none"> <li>35 mm concrete</li> <li>0.38 mm thick steel deck with 15.9 mm deep corrugations</li> <li>203 mm deep steel joist with 1.22 mm material thickness and spaced at 406 mm o.c.</li> <li>resilient metal channels spaced 610 mm o.c.</li> <li>89 mm thick glass fibre insulation</li> <li>2 layers of 12.7 mm Type X gypsum board on ceiling side</li> </ul>			
		61 min	66 <sup>a</sup>	34 <sup>b</sup>
NRCC RR-184 FF50  a) TLF-04-029a b) IIF-04-016	<ul style="list-style-type: none"> <li>2 layers of 15.5 mm plywood subfloor</li> <li>203 mm deep steel joist with 1.22 mm material thickness and spaced at 406 mm o.c.</li> <li>91 mm thick cellulose fibre insulation on joist sides and 112 mm on underside of subfloor</li> <li>resilient metal channels spaced 406 mm o.c.</li> <li>1 layer of 12.7 mm Type X gypsum board on ceiling side</li> </ul>			
		63 min	51 <sup>a</sup>	45 <sup>b</sup>

## Floor/Ceiling – National Research Council of Canada

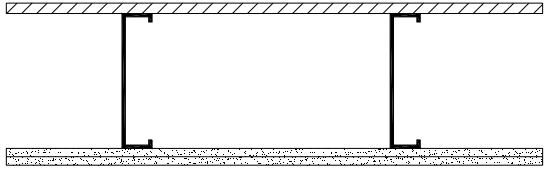
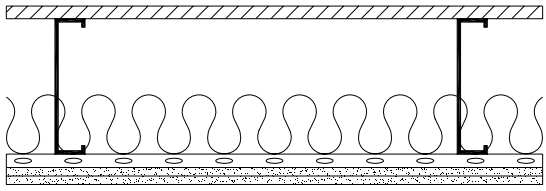
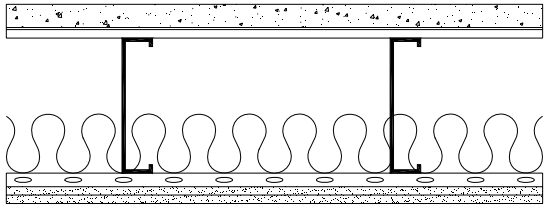
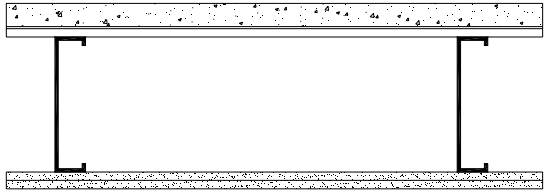
Source	Description	Fire Endurance	Sound Transmission Class	Impact Insulation Class
NRCC RR-184 FF51	<ul style="list-style-type: none"> <li>subfloor of 15.5 mm plywood</li> <li>203 mm deep steel joist with 1.22 mm material thickness and spaced at 406 mm o.c.</li> <li>2 layers of 12.7 mm Type X gypsum board on ceiling side</li> </ul>			
		66 min	-	-
NRCC RR-184 FF52	<ul style="list-style-type: none"> <li>subfloor of 19 mm plywood</li> <li>203 mm deep steel joist with 1.22 mm material thickness and spaced at 610 mm o.c.</li> <li>89 mm thick glass fibre insulation</li> <li>resilient metal channels spaced 610 mm o.c.</li> <li>2 layers of 12.7 mm Type X gypsum board on ceiling side</li> </ul>			
		52 min	-	-
NRCC RR-184 FF53  a) TLF-03-007a b) IIF-03-004	<ul style="list-style-type: none"> <li>35 mm concrete</li> <li>0.38 mm thick steel deck with 15.9 mm deep corrugations</li> <li>203 mm deep steel joist with 1.22 mm material thickness and spaced at 406 mm o.c.</li> <li>resilient metal channels spaced 406 mm o.c.</li> <li>89 mm thick rock fibre insulation</li> <li>2 layers of 12.7 mm Type X gypsum board on ceiling side</li> </ul>			
		70 min	68 <sup>a</sup>	37 <sup>b</sup>
NRCC RR-184 FF54	<ul style="list-style-type: none"> <li>35 mm concrete</li> <li>0.38 mm thick steel deck with 15.9 mm deep corrugations</li> <li>203 mm deep steel joist with 1.22 mm material thickness and spaced at 610 mm o.c.</li> <li>2 layers of 12.7 mm Type X gypsum board on ceiling side</li> </ul>			
		66 min	-	-

## Floor/Ceiling – National Research Council of Canada

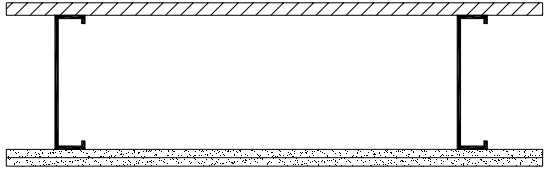
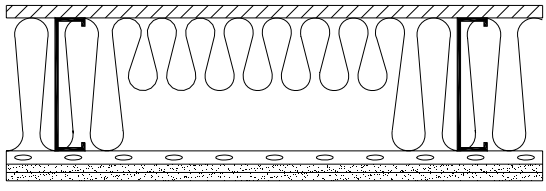
Source	Description	Fire Endurance	Sound Transmission Class	Impact Insulation Class
NRCC RR-184 FF62	<ul style="list-style-type: none"> <li>subfloor of 19 mm plywood</li> <li>203 mm deep steel joist with 1.22 mm material thickness and spaced at 610 mm o.c.</li> <li>2 layers of 12.7 mm Type X gypsum board on ceiling side</li> </ul>			
		54 min	-	-
NRCC RR-184 FF65  a) TLF-04-011a b) IIF-04-007	<ul style="list-style-type: none"> <li>subfloor of 19 mm plywood</li> <li>203 mm deep steel joist with 1.22 mm material thickness and spaced at 610 mm o.c.</li> <li>100 mm thick cellulose fibre insulation on joist sides and 94 mm on underside of subfloor</li> <li>resilient metal channels spaced 610 mm o.c.</li> <li>2 layers of 12.7 mm Type X gypsum board on ceiling side</li> </ul>			
		68 min	57 <sup>a</sup>	51 <sup>b</sup>

## Floor/Ceiling – National Research Council of Canada

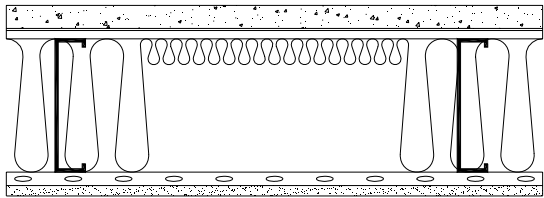
Source	Description	Fire Endurance	Sound Transmission Class	Impact Insulation Class
NRCC RR-184 FF74	<ul style="list-style-type: none"> <li>• 35 mm concrete</li> <li>• 0.38 mm thick steel deck with 15.9 mm deep corrugations</li> <li>• 203 mm deep steel joist with 1.22 mm material thickness and spaced at 610 mm o.c.</li> <li>• resilient metal channels spaced 406 mm o.c.</li> <li>• 89 mm thick cellulose fibre insulation on joist sides and 38 mm on underside of subfloor</li> <li>• 1 layer of 15.9 mm Type X gypsum board on ceiling side</li> </ul>			
		56 min	63*	29*

\* Estimated value as per Warnock (2008)

### References:

Sultan, M.A., Latour, J.C., Leroux, P., Monette, R.C., Séguin, Y.P. and Henrie, J.P., *Results of Fire Resistance Tests on Full-Scale Floor Assemblies – Phase II, Research Report No. 184 (RR-184)*, Institute for Research in Construction, National Research Council of Canada, Ottawa, Ontario, Canada, March 2005.

Warnock, A.C.C., *Summary Report for Consortium on Fire Resistance and Sound Insulation of Floors: Sound Transmission and Impact Insulation Data, Research Report No. 169 (RR-169)*, Institute for Research in Construction, National Research Council of Canada, Ottawa, Ontario, Canada, January 2005.

\* Warnock, A.C.C., *Estimation of Sound Transmission Class and Impact Insulation Class Rating for Steel Framed Assemblies*, Report No. B3436.1, Institute for Research in Construction, National Research Council of Canada, Ottawa, Ontario, Canada, December 2005.

Floor/Ceiling – Underwriters Laboratories Inc.

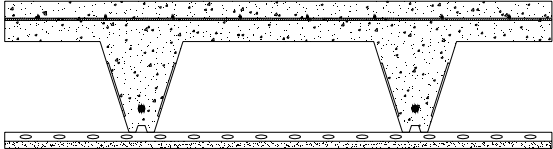
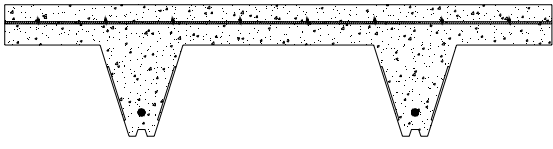
Source	Description	Fire Resistance Rating	Sound Transmission Class	Impact Insulation Class
<p><b>UL D504</b></p> <p>K.E. Barron, P.Eng. 98-02-10 report available from Bailey Metal Products Ltd.</p>	<ul style="list-style-type: none"> <li>min. 3 <sup>9</sup>/<sub>16</sub>" concrete topping</li> <li>6" by 6" W2.9/W2.9 welded wire fabric</li> <li>steel reinforcing bar with 1 <sup>19</sup>/<sub>32</sub>" concrete cover</li> <li>composite galvanized fluted units, <b>proprietary</b> 8" deep COMFLOR® 210 or SLIMDEK® 225 with min. 20 MSG by Bailey Metal Products Ltd.</li> <li>furring channels spaced 16" o.c.</li> <li>1 layer of 5/8" gypsum board on ceiling side</li> </ul> <p>* for steel deck span &gt; 32' - 9 <sup>5</sup>/<sub>8</sub>"  ** for steel deck span ≤ 32' - 9 <sup>5</sup>/<sub>8</sub>"  *** Field obtained STC</p>		<p>1-1/2 h * 2 h **</p>	<p>57***</p> <p>-</p>
<p><b>UL D930</b></p> <p>K.E. Barron, P.Eng. 98-02-10 report available from Bailey Metal Products Ltd.</p>	<ul style="list-style-type: none"> <li>2 1/2" concrete topping for 1 h and 3 <sup>9</sup>/<sub>16</sub>" for 1 1/2 h</li> <li>6" by 6" W2.9/W2.9 welded wire fabric</li> <li>steel reinforcing bar with 1 <sup>19</sup>/<sub>32</sub>" concrete cover</li> <li>composite galvanized fluted units, <b>proprietary</b> 8 1/4" deep COMFLOR® 210 or SLIMDEK® 225 with a min. 20 MSG by Bailey Metal Products Ltd.</li> </ul> <p>* for steel deck span ≤ 32' - 9 <sup>5</sup>/<sub>8</sub>"  ** Field obtained STC</p>		<p>1 h * 1-1/2 h *</p>	<p>55**</p> <p>-</p>

Floor/Ceiling – Underwriters Laboratories Inc.

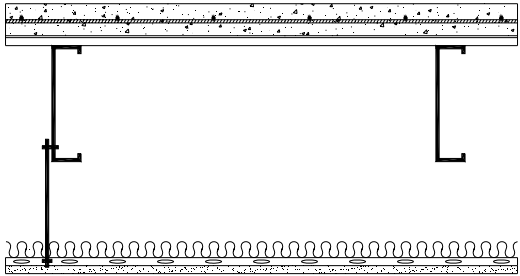
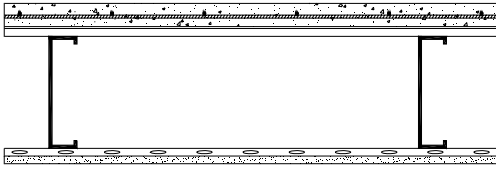
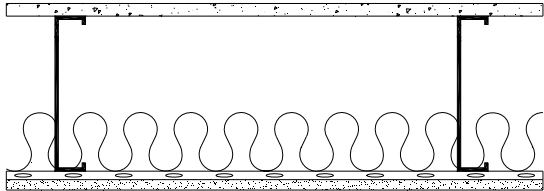
Source	Description	Fire Resistance Rating	Sound Transmission Class	Impact Insulation Class
UL G533	<ul style="list-style-type: none"> <li>• 2" lightweight concrete with 3400 psi comp. strength</li> <li>• welded wire fabric, 6" by 6", W1.4 x W1.4</li> <li>• 0.018" thick steel deck with 19/32" deep corrugations</li> <li>• 7 3/16" x 18 MSG steel joist spaced at 24" o.c.</li> <li>• 26 MSG furring channels spaced 24" o.c.</li> <li>• 1" thick mineral wool batts</li> <li>• 1 layer of 1/2" gypsum board on ceiling side</li> </ul>			
2 h	-			
UL G534	<ul style="list-style-type: none"> <li>• 1 1/2" min. lightweight concrete with 3400 psi comp. strength</li> <li>• welded wire fabric, 6" by 6", 10/10 SWG</li> <li>• 0.018" thick steel deck with 19/32" deep corrugations</li> <li>• 7 3/16" x 18 MSG steel joist spaced at 24" o.c.</li> <li>• 26 MSG furring channels spaced 24" o.c.</li> <li>• 1 layer of 1/2" gypsum board on ceiling side</li> </ul>			
1 h	-			
UL G535	<ul style="list-style-type: none"> <li>• subfloor of 3/4" thick tongue-and-groove cement-fibre board designated "Fortacrete"</li> <li>• 1/2" gypsum board or 3/4" topping mixture on top of subfloor for 2 hour</li> <li>• 9 1/4" x 16 MSG <b>proprietary</b> steel joist (Dietrich Industries Inc.) spaced at 24" o.c.</li> <li>• 3 5/8" glass fiber batt insulation</li> <li>• resilient metal channels spaced 12" o.c.</li> <li>• 1 layer of 5/8" gypsum board on ceiling side</li> </ul>			
1-1/2 h 2 h	-			

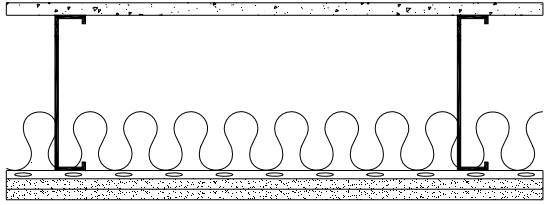
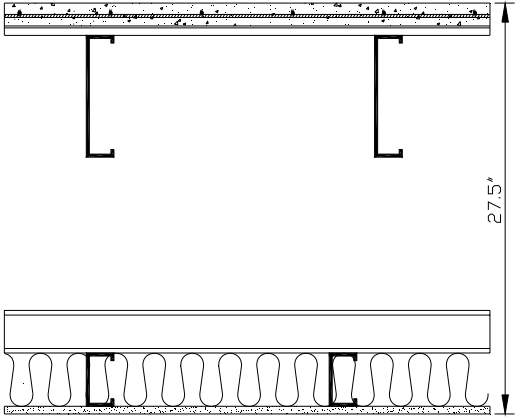

**Floor/Ceiling – Underwriters Laboratories Inc.**

Source	Description	Fire Resistance Rating	Sound Transmission Class	Impact Insulation Class
<p>UL G536</p>	<ul style="list-style-type: none"> <li>• subfloor of 3/4" thick tongue-and-groove cement-fibre board designated "Fortacrete"</li> <li>• 9 1/4" x 16 MSG <b>proprietary</b> steel joist (Dietrich Industries Inc.) spaced at 24" o.c.</li> <li>• 3 5/8" glass fiber batt insulation</li> <li>• resilient metal channels spaced 12" o.c.</li> <li>• 2 layers of 5/8" gypsum board on ceiling side</li> </ul>			
		2 h	-	-
<p>UL G537</p>	<ul style="list-style-type: none"> <li>• 1 1/2" min. lightweight or normal-weight concrete with 3400 psi and 3500 psi comp. strength, respectively</li> <li>• welded wire fabric, 6" by 6", W1.4 x W1.4</li> <li>• expanded steel lath with 3/8" rib</li> <li>• 8" x 18 gauge steel joist spaced at 19" o.c.</li> <li>• 3 1/2" x 18 gauge ceiling joists spaced 16" o.c.</li> <li>• insulation optional, 3 1/2" mineral wool loose fill for 1 h and 3 1/2" fiberglass required for 1-1/2 h</li> <li>• 1 layer of 1/2" gypsum board on ceiling side</li> </ul>			
		1 h 1-1/2 h	-	-

Floor/Ceiling – Underwriters Laboratories Inc.

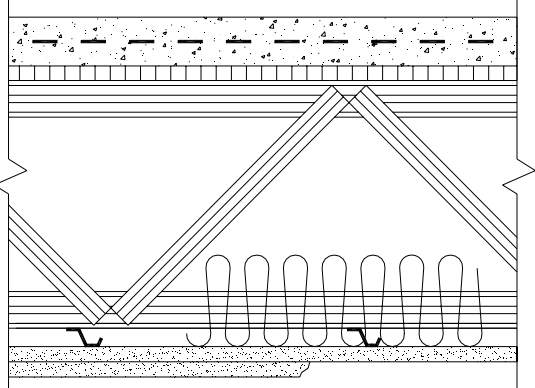
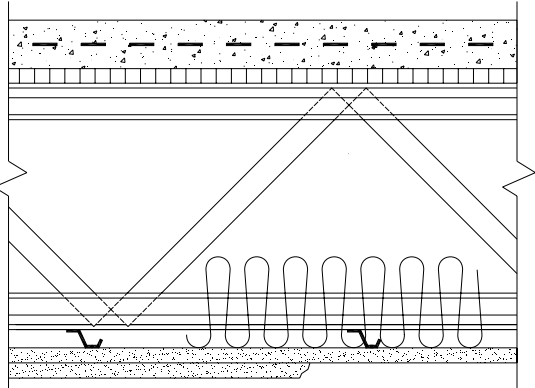
Source	Description	Fire Resistance Rating	Sound Transmission Class	Impact Insulation Class
<p>UL G540</p>	<ul style="list-style-type: none"> <li>• 2" min. normal or lightweight concrete with 3000 psi comp. strength</li> <li>• welded wire fabric, 6" by 6", 10/10 SWG</li> <li>• expanded steel lath with 3/8" rib</li> <li>• <b>proprietary</b> pre-fabricated light gauge steel truss system, Ultra-Span by Aegis Metal Framing, spaced at 48" o.c.</li> <li>• resilient or furring channels spaced 16" o.c.</li> <li>• any thickness mineral wool or glass fiber insulation, optional for 1 h and omitted for 2 h</li> <li>• 1 hour - 1 layer of 5/8" gypsum board on ceiling side</li> <li>• 2 hour – 2 layers of 5/8" gypsum board on ceiling side</li> </ul>	 <p>1 h 2 h</p>	-	-
<p>UL G542</p>	<ul style="list-style-type: none"> <li>• 2" min. normal or lightweight concrete with 3000 psi comp. strength</li> <li>• welded wire fabric, 6" by 6", 10/10 SWG</li> <li>• expanded steel lath with 3/8" rib</li> <li>• <b>proprietary</b> pre-fabricated light gauge steel truss system, TrusSteel by Alpine Engineered Products, Inc., spaced at 48" o.c.</li> <li>• resilient or furring channels spaced 16" o.c.</li> <li>• any thickness mineral wool or glass fiber insulation, optional for 1 h and omitted for 2 h</li> <li>• 1 hour - 1 layer of 5/8" gypsum board on ceiling side</li> <li>• 2 hour – 2 layers of 5/8" gypsum board on ceiling side</li> </ul>	 <p>1 h 2 h</p>	-	-

Floor/Ceiling – Underwriters Laboratories Inc.

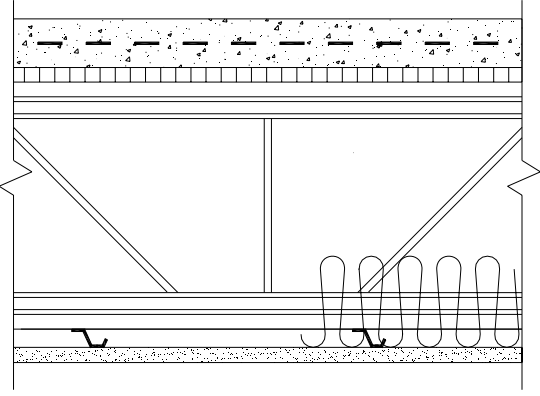
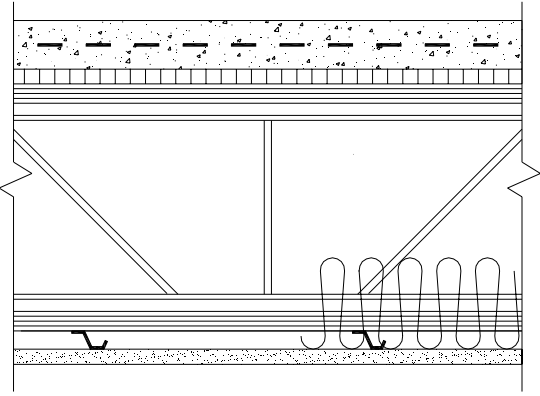
Source	Description	Fire Resistance Rating	Sound Transmission Class	Impact Insulation Class
<p>UL G543</p>	<ul style="list-style-type: none"> <li>• 2" min. normal or lightweight concrete with 3000 psi comp. strength</li> <li>• welded wire fabric, 6" by 6", 10/10 SWG</li> <li>• expanded steel lath with 3/8" rib</li> <li>• <b>proprietary</b> pre-fabricated light gauge steel truss system, Amkey System by Allied Studco, spaced at 48" o.c.</li> <li>• resilient channels spaced 16" o.c.</li> <li>• any thickness mineral wool or glass fiber insulation, optional</li> <li>• 1 layer of 5/8" gypsum board on ceiling side</li> </ul>		<p>1 h</p>	<p>-</p>
<p>UL G544</p>	<ul style="list-style-type: none"> <li>• 2" min. normal or lightweight concrete with 3000 psi comp. strength</li> <li>• welded wire fabric, 6" by 6", 10/10 SWG</li> <li>• expanded steel lath with 3/8" rib</li> <li>• <b>proprietary</b> pre-fabricated light gauge steel truss system, Versa-Truss by Dale/Incor, spaced at 48" o.c.</li> <li>• resilient channels spaced 16" o.c.</li> <li>• any thickness mineral wool or glass fiber insulation, optional</li> <li>• 1 layer of 5/8" gypsum board on ceiling side</li> </ul>		<p>1 h</p>	<p>-</p>

Floor/Ceiling – Underwriters Laboratories Inc.

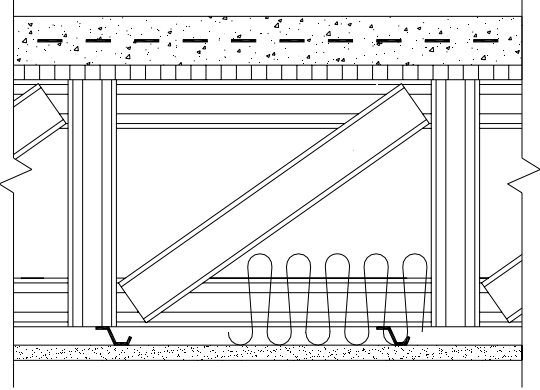
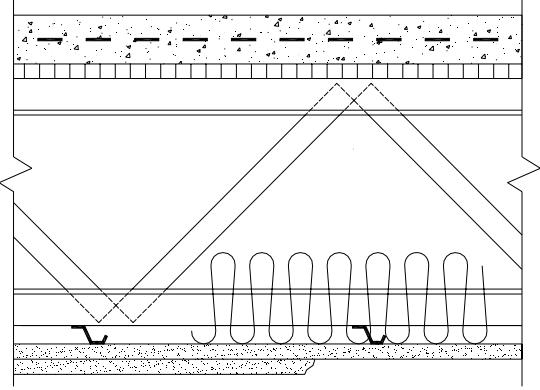
Source	Description	Fire Resistance Rating	Sound Transmission Class	Impact Insulation Class
UL G545	<ul style="list-style-type: none"> <li>• 2" min. normal or lightweight concrete with 3000 psi comp. strength</li> <li>• welded wire fabric, 6" by 6", 10/10 SWG</li> <li>• expanded steel lath with 3/8" rib</li> <li>• <b>proprietary</b> pre-fabricated light gauge steel truss system, Strong-Span by Hexaport International Ltd., spaced at 48" o.c.</li> <li>• resilient or furring channels spaced 16" o.c.</li> <li>• any thickness mineral wool or glass fiber insulation, optional for 1 h only</li> <li>• 1 layer of 5/8" gypsum board on ceiling side</li> </ul>		-	-
UL G546	<ul style="list-style-type: none"> <li>• 2" min. normal or lightweight concrete with 3000 psi comp. strength</li> <li>• welded wire fabric, 6" by 6", 10/10 SWG</li> <li>• expanded steel lath with 3/8" rib</li> <li>• <b>proprietary</b> pre-fabricated light gauge steel truss system, Gus Truss by Nucon Steel Corporation, spaced at 48" o.c.</li> <li>• resilient or furring channels spaced 16" o.c.</li> <li>• any thickness mineral wool or glass fiber insulation, optional for 1 h and omitted for 2 h</li> <li>• 1 hour - 1 layer of 5/8" gypsum board on ceiling side</li> <li>• 2 hour – 2 layers of 5/8" gypsum board on ceiling side</li> </ul>		-	-
		2 h		
		1 h 2 h		

**Floor/Ceiling – Underwriters Laboratories Inc.**

Source	Description	Fire Resistance Rating	Sound Transmission Class	Impact Insulation Class												
<p>UL G549</p> <p>a) TLF-02-051a b) IIF-02-032</p>	<ul style="list-style-type: none"> <li>1 3/8" concrete</li> <li>28 ga (0.015" thick) steel deck with 5/8" deep corrugations</li> <li>8" x 18 MSG steel joist spaced at 16" o.c. or 24" o.c.</li> <li>optional resilient metal channels spaced 24" o.c.</li> <li>optional 3 1/2" mineral wool or glass fiber batt insulation</li> <li>2 layers of 1/2" gypsum board on ceiling side</li> </ul>	<p style="text-align: center;">Spaced max 24 in. OC</p> <p style="text-align: center;">Spaced max 16 in. OC</p>														
		1 h	<table border="1" style="width: 100%; text-align: center;"> <tr> <th colspan="2" style="text-align: left;">24" joist spacing</th> </tr> <tr> <td style="width: 50%;">65* (GFB RC)</td> <td style="width: 50%;">29* (GFB RC)</td> </tr> <tr> <td>60* (NI RC)</td> <td>30* (NI RC)</td> </tr> <tr> <th colspan="2" style="text-align: left;">16" joist spacing</th> </tr> <tr> <td>66<sup>a</sup> (GFB RC)</td> <td>34<sup>b</sup> (GFB RC)</td> </tr> <tr> <td>60* (NI RC)</td> <td>&lt;30* (NI RC)</td> </tr> </table>		24" joist spacing		65* (GFB RC)	29* (GFB RC)	60* (NI RC)	30* (NI RC)	16" joist spacing		66 <sup>a</sup> (GFB RC)	34 <sup>b</sup> (GFB RC)	60* (NI RC)	<30* (NI RC)
24" joist spacing																
65* (GFB RC)	29* (GFB RC)															
60* (NI RC)	30* (NI RC)															
16" joist spacing																
66 <sup>a</sup> (GFB RC)	34 <sup>b</sup> (GFB RC)															
60* (NI RC)	<30* (NI RC)															
<p>UL G551</p>	<ul style="list-style-type: none"> <li>1" min. floor topping mixture with 3500 psi comp. strength</li> <li>9/16" min. deep, 22 MSG corrugated fluted steel deck</li> <li>9 1/4" x 16 MSG <b>proprietary</b> steel joist (Dietrich Industries Inc.) spaced at 24" o.c.</li> <li>resilient metal channels spaced 12" o.c.</li> <li>3 1/2" mineral wool or glass fiber batt insulation</li> <li>1 hour - 1 layer of 5/8" gypsum board on ceiling side</li> <li>2 hour – 2 layers of 5/8" gypsum board on ceiling side</li> </ul>															
		1 h 2 h	-	-												

\* Estimated value as per Warnock (2008)

Floor/Ceiling – Underwriters Laboratories Inc.

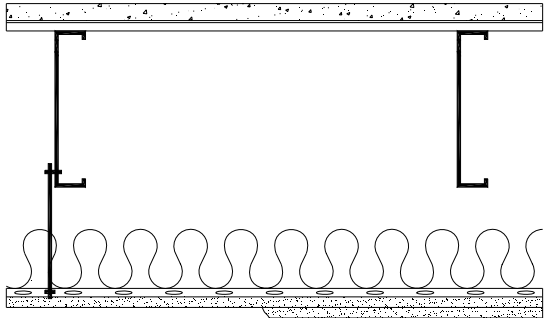
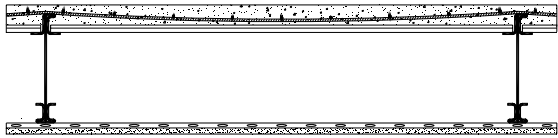
Source	Description	Fire Resistance Rating	Sound Transmission Class	Impact Insulation Class
<p>UL G553</p>	<ul style="list-style-type: none"> <li>• 1" min. floor topping mixture with 3500 psi comp. strength</li> <li>• 9/16" min. deep, 22 MSG corrugated fluted steel deck</li> <li>• 9 1/4" x 16 MSG <b>proprietary</b> steel joist (Dietrich Industries Inc.) spaced at 24" o.c.</li> <li>• hanger wire 12 SWG at 48" o.c.</li> <li>• resilient metal channels spaced 12" o.c.</li> <li>• 3 1/2" mineral wool or glass fiber batt insulation</li> <li>• 1 hour - 1 layer of 5/8" gypsum board on ceiling side</li> <li>• 2 hour – 2 layers of 5/8" gypsum board on ceiling side</li> </ul>			
		<p>1 h 2 h</p>	<p>-</p>	<p>-</p>
<p>UL G555</p>	<ul style="list-style-type: none"> <li>• 2 3/4" concrete slab with 6" by 6" MW13.3/MW13.3 welded wire fabric on 0.030" thick steel deck with 0.875" deep corrugations</li> <li>• 11" deep <b>proprietary</b> composite steel joist, iSPAN™ licensed by Genesis TP in USA and Canada, with 0.058" material thickness and spaced at 48" o.c.</li> <li>• furring channels spaced 16" o.c.</li> <li>• 1 layer of 5/8" gypsum board on ceiling side</li> </ul>			
		<p>2 h</p>	<p>50 (2 3/4" slab) 53 (4 1/4" slab)</p>	<p>25 (2 3/4" slab) 34 (4 1/4" slab)</p>

**Floor/Ceiling – Underwriters Laboratories Inc.**

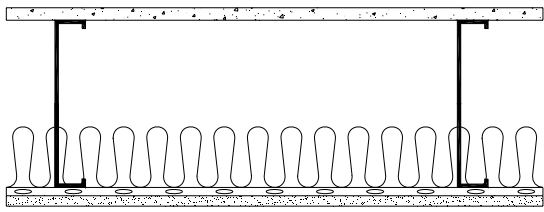
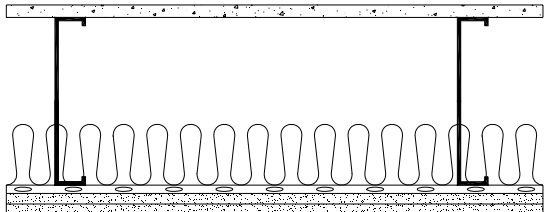
Source	Description	Fire Resistance Rating	Sound Transmission Class	Impact Insulation Class
UL G556	<ul style="list-style-type: none"> <li>• subfloor of ¾" thick tongue-and-groove cement-fibre board designated "Fortacrete"</li> <li>• ½" gypsum board or ¾" topping mixture on top of subfloor for 2 h</li> <li>• 10" x 16 MSG steel joist for 1-½ h and 6" x 18 MSG or 8" x 16 MSG for 1 h, spaced at 24" o.c.</li> <li>• 3 ⅝" glass fiber batt insulation</li> <li>• resilient metal channels spaced 12" o.c.</li> <li>• 1 layer of ⅝" gypsum board on ceiling side</li> </ul>		-	-
UL G557	<ul style="list-style-type: none"> <li>• subfloor of ¾" thick tongue-and-groove cement-fibre board designated "Fortacrete"</li> <li>• 10" x 16 MSG, 6" x 18 MSG or 8" x 16 MSG steel joist spaced at 24" o.c.</li> <li>• 3 ⅝" glass fiber batt insulation</li> <li>• resilient metal channels spaced 12" o.c.</li> <li>• 2 layers of ⅝" gypsum board on ceiling side</li> </ul>		-	-

**Floor/Ceiling – Underwriters Laboratories Inc.**

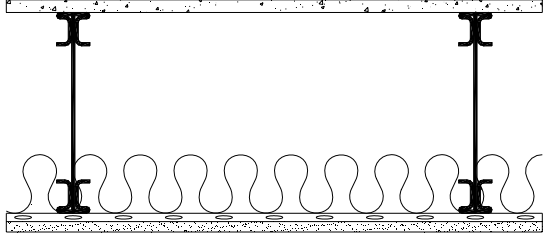
Source	Description	Fire Resistance Rating	Sound Transmission Class	Impact Insulation Class
UL G558	<ul style="list-style-type: none"> <li>• subfloor of 3/4" thick tongue-and-groove cement-fibre board designated "Fortacrete"</li> <li>• 12" deep <b>proprietary</b> steel joist, iSPAN™ licensed by Genesis TP in USA and Canada, with 18 ga material thickness and spaced at 24" o.c.</li> <li>• resilient metal channels spaced 12" o.c.</li> <li>• 3 1/2" glass fiber batt insulation</li> <li>• 1 layer of 5/8" gypsum board on ceiling side</li> </ul>		1 h	56*
UL G559	<ul style="list-style-type: none"> <li>• 1" min. floor topping mixture with 3500 psi comp. strength</li> <li>• 9/16" min. deep, 22 MSG corrugated fluted steel deck</li> <li>• 9 1/4" x 16 MSG <b>proprietary</b> steel joist (CEMCO) spaced at 24" o.c.</li> <li>• resilient metal channels spaced 12" o.c.</li> <li>• 3 1/2" glass fiber batt insulation</li> <li>• 1 layer of 5/8" gypsum board on ceiling side</li> </ul>			
		2 h	-	-

\* Brunette, N.L., Airborne Sound Transmission Loss and Impact Sound Transmission Measurements Performed on One Floor Assembly, NRC Client Report B-3454.1, National Research Council of Canada, Ottawa, Ontario, Canada, 2007.

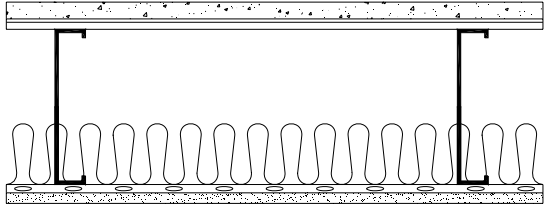
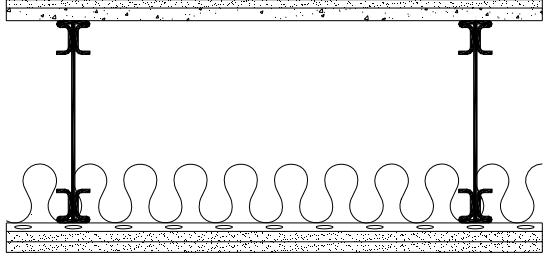

**Floor/Ceiling – Underwriters Laboratories Inc.**

Source	Description	Fire Resistance Rating	Sound Transmission Class	Impact Insulation Class
UL G560	<ul style="list-style-type: none"> <li>• 1" min. floor topping mixture with 3500 psi comp. strength</li> <li>• 9/16" min. deep, 22 MSG corrugated fluted steel deck</li> <li>• 9¼" deep steel joist with 0.055" material thickness and spaced at 24" o.c.</li> <li>• resilient metal channels spaced 12" o.c.</li> <li>• 3½" mineral wool or glass fiber batt insulation</li> <li>• 1 layer of 5/8" gypsum board on ceiling side</li> </ul>			
UL G562	<ul style="list-style-type: none"> <li>• subfloor of ¾" thick tongue-and-groove cement-fibre board designated "Fortacrete" topped with ½" thick gypsum board (System A) or ¾" thick floor topping mixture (System B)</li> <li>• 12" deep <b>proprietary</b> steel joist, iSPAN™ licensed by Genesis TP in USA and Canada, with 18 ga material thickness and spaced at 24" o.c.</li> <li>• resilient metal channels spaced 12" o.c.</li> <li>• 3½" glass fiber batt insulation</li> <li>• 2 layers of 5/8" mm gypsum board on ceiling side</li> </ul>			

\* Brunette, N.L., Airborne Sound Transmission Loss and Impact Sound Transmission Measurements Performed on One Floor Assembly, NRC Client Report B-3454.6, National Research Council of Canada, Ottawa, Ontario, Canada, 2007.

Floor/Ceiling – Underwriters Laboratories Inc.

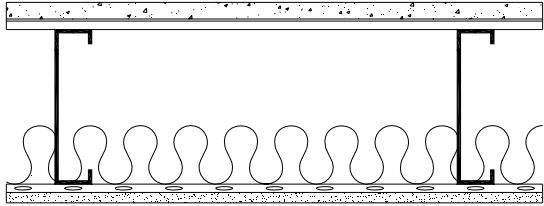
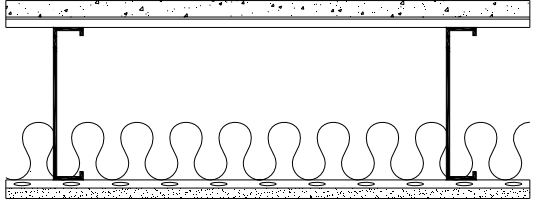
Source	Description	Fire Resistance Rating	Sound Transmission Class	Impact Insulation Class
UL G563	<ul style="list-style-type: none"> <li>• 1" min. floor topping mixture with 3500 psi comp. strength</li> <li>• 9/16" min. deep, 22 MSG corrugated fluted steel deck</li> <li>• 9¼" x 16 MSG <b>proprietary</b> steel joist (Marino\WARE) spaced at 24" o.c.</li> <li>• resilient metal channels spaced at 12" o.c.</li> <li>• 3½" glass fiber batt insulation</li> <li>• 1 layer of 5/8" gypsum board on ceiling side</li> </ul>			
2 h	-			
UL G574	<ul style="list-style-type: none"> <li>• 1" min. floor topping mixture with 3500 psi comp. strength</li> <li>• 9/16" min. deep, 22 MSG corrugated fluted steel deck</li> <li>• 9¼" x 16 MSG <b>proprietary</b> steel joist (CEMCO) spaced at 24" o.c.</li> <li>• resilient metal channels spaced 12" o.c.</li> <li>• 3 ½" glass fiber batt insulation</li> <li>• 1 layer of 5/8" gypsum board on ceiling side</li> </ul>			
2 h	-			

**Floor/Ceiling – Underwriters Laboratories Inc.**

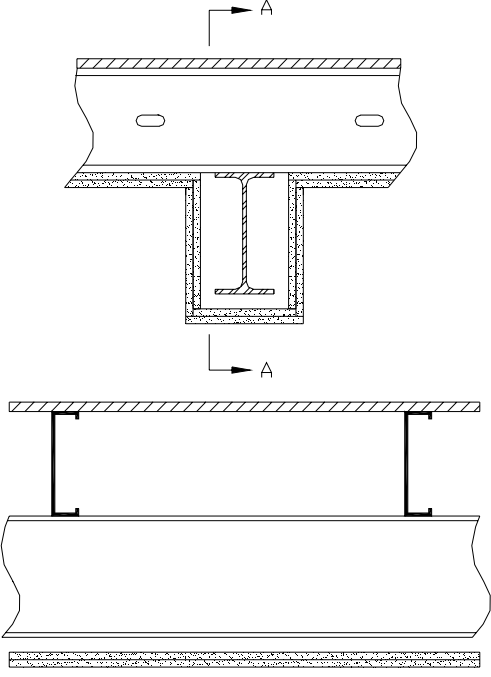
Source	Description	Fire Resistance Rating	Sound Transmission Class	Impact Insulation Class
<p>UL L524</p> <p>a) USG760105 b) USG760310 c) USG760106 d) USG760405</p>	<p>Steel Beam – W8x15 min. size</p> <ul style="list-style-type: none"> <li>• subfloor of <math>1\frac{19}{32}</math>" plywood</li> <li>• 7" x 18 MSG steel joist spaced at 24" o.c.</li> <li>• 2 layers of <math>\frac{1}{2}</math>" gypsum board on ceiling side</li> </ul> <p>a) Based on <math>9\frac{1}{2}</math>" 16 gauge steel joists b) Based on <math>9\frac{1}{2}</math>" 16 gauge steel joists and 3" mineral wool batt c) Based on <math>9\frac{1}{2}</math>" 16 gauge steel joists and carpet pad d) Based on <math>9\frac{1}{2}</math>" 16 gauge steel joists and carpet pad with 3" mineral wool batt</p>	 <p style="text-align: center;">Section A-A</p>	<p>1 h</p> <p>39<sup>a</sup> 43<sup>b</sup> 56<sup>c</sup> 60<sup>d</sup></p>	<p>-</p>

## Floor/Ceiling – Underwriters Laboratories Inc.

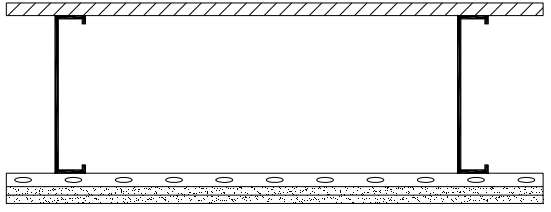
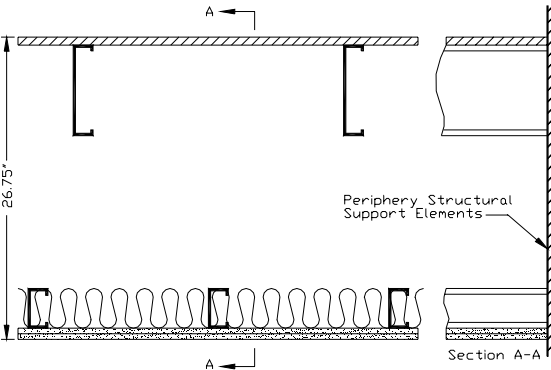
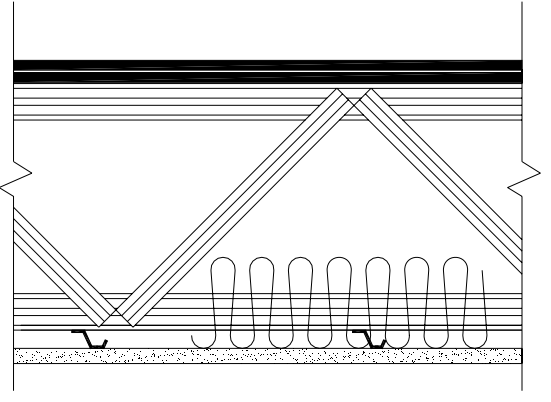
Source	Description	Fire Resistance Rating	Sound Transmission Class	Impact Insulation Class	
UL L527  a) USG771101 b) SA781110	<ul style="list-style-type: none"> <li>subfloor of 3/4" plywood</li> <li>9 3/8" x 16 MSG steel joist spaced at 24" o.c.</li> <li>24 ga metal resilient channels spaced 16" o.c.</li> <li>2 layers of 5/8" gypsum board on ceiling side</li> </ul>		1-1/2 h	48 <sup>a</sup> 51 <sup>b</sup> (CAR-UND)	<40* 70* (CAR-UND)
UL L543	<ul style="list-style-type: none"> <li>subfloor of 23/32" plywood</li> <li>8" x 18 MSG steel joist spaced at 19" o.c.</li> <li>3 1/2" x 18 MSG ceiling steel joists spaced at 16" o.c.</li> <li>3 1/2" mineral wool insulation</li> <li>2 layers of 1/2" gypsum board on ceiling side</li> </ul>		1 h	> 60*	> 50*
UL L549	<ul style="list-style-type: none"> <li>2 layer flooring system (9 types)</li> <li><b>proprietary</b> pre-fabricated light gauge steel truss system, Ultra-Span by Aegis Metal Framing, spaced at 48" o.c.</li> <li>resilient or furring channels spaced 16" o.c.</li> <li>any thickness mineral wool or glass fiber insulation, optional</li> <li>1 layer of 5/8" gypsum board on ceiling side</li> </ul>		1 h	-	-

\* Estimated value as per Warnock (2008)

Floor/Ceiling – Underwriters Laboratories Inc.

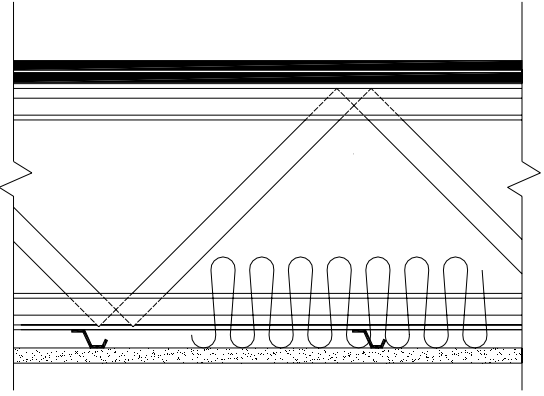
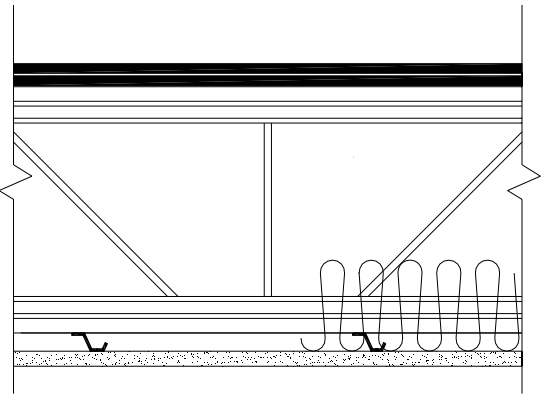
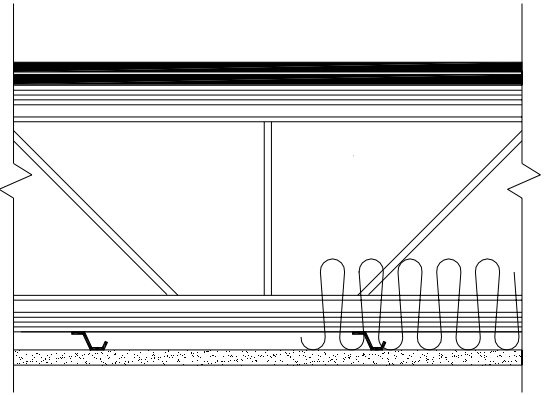
Source	Description	Fire Resistance Rating	Sound Transmission Class	Impact Insulation Class
UL L551	<ul style="list-style-type: none"> <li>• 2 layer flooring system (9 types)</li> <li>• <b>proprietary</b> pre-fabricated light gauge steel truss system, TrusSteel by Alpine Engineered Products, Inc., spaced at 48" o.c.</li> <li>• resilient or furring channels spaced 16" o.c.</li> <li>• any thickness mineral wool or glass fiber insulation, optional</li> <li>• 1 layer of 5/8" gypsum board on ceiling side</li> </ul>		1 h	-
UL L552	<ul style="list-style-type: none"> <li>• 2 layer flooring system (9 types)</li> <li>• <b>proprietary</b> pre-fabricated light gauge steel truss system, Amkey System by Allied Studco, spaced at 48" o.c.</li> <li>• resilient channels spaced 16" o.c.</li> <li>• any thickness mineral wool or glass fiber insulation, optional</li> <li>• 1 layer of 5/8" gypsum board on ceiling side</li> </ul>		1 h	-
UL L553	<ul style="list-style-type: none"> <li>• 2 layer flooring system (9 types)</li> <li>• <b>proprietary</b> pre-fabricated light gauge steel truss system, Versa-Truss by Dale/Incor, spaced at 48" o.c.</li> <li>• resilient channels spaced 16" o.c.</li> <li>• any thickness mineral wool or glass fiber insulation, optional</li> <li>• 1 layer of 5/8" gypsum board on ceiling side</li> </ul>		1 h	-

Floor/Ceiling – Underwriters Laboratories Inc.

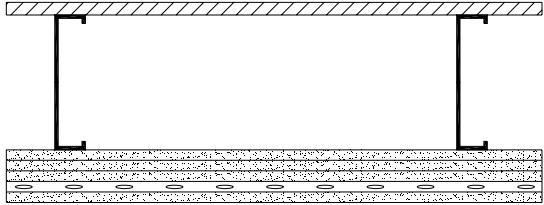
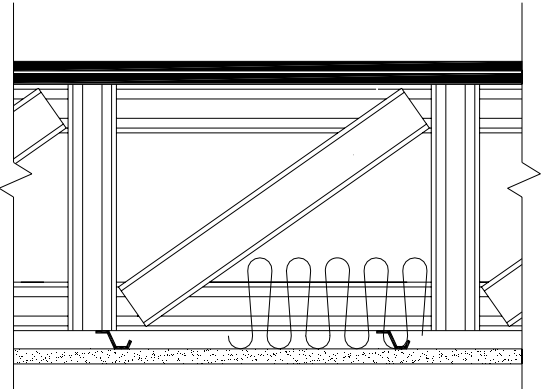
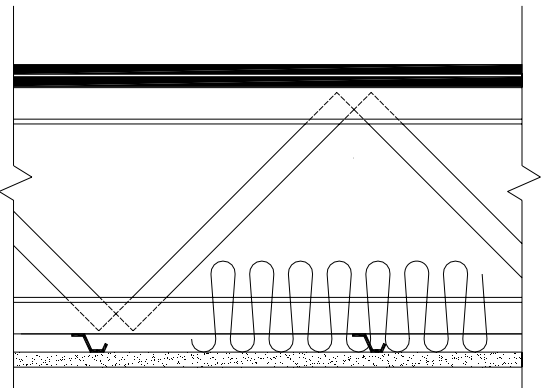
Source	Description	Fire Resistance Rating	Sound Transmission Class	Impact Insulation Class
<p>UL L556</p> <p>a) NGC5004021 b) NGC7004068 c) NGC7004069</p>	<ul style="list-style-type: none"> <li>• subfloor of 3/4" plywood</li> <li>• 8" x 18 MSG steel joist spaced at 24" o.c.</li> <li>• 4 layers of 5/8" Type X gypsum board on ceiling side</li> <li>• resilient metal channels spaced 24" o.c. and applied perpendicular to joists over third layer of gypsum board</li> </ul>			
		2 h	48 <sup>a</sup>	37 <sup>b</sup> 60 <sup>c</sup> (CAR-UND)
<p>UL L559</p>	<ul style="list-style-type: none"> <li>• 2 layer flooring system (9 types)</li> <li>• <b>proprietary</b> pre-fabricated light gauge steel truss system, Strong-Span by Hexaport International Ltd., spaced at 48" o.c.</li> <li>• resilient or furring channels spaced 16" o.c.</li> <li>• any thickness mineral wool or glass fiber insulation, optional</li> <li>• 1 layer of 5/8" gypsum board on ceiling side</li> </ul>			
		1 h	-	-
<p>UL L560</p>	<ul style="list-style-type: none"> <li>• 2 layer flooring system (9 types)</li> <li>• <b>proprietary</b> pre-fabricated light gauge steel truss system, Gus Truss by Nucon Steel Corporation, spaced at 48" o.c.</li> <li>• resilient or furring channels spaced 16" o.c.</li> <li>• any thickness mineral wool or glass fiber insulation, optional</li> <li>• 1 layer of 5/8" gypsum board on ceiling side</li> </ul>			
		1 h	-	-

Floor/Ceiling – Underwriters Laboratories Inc.

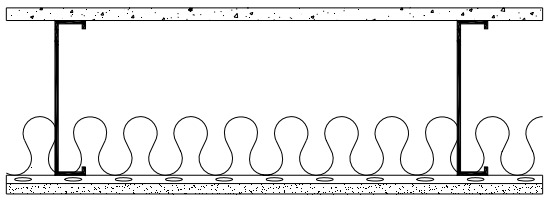
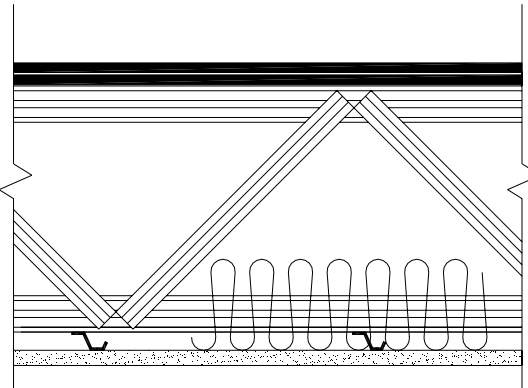
Source	Description	Fire Resistance Rating	Sound Transmission Class	Impact Insulation Class
UL L564	<ul style="list-style-type: none"> <li>• subfloor of 3/4" cement-fiber unit</li> <li>• 9 1/4" x 16 MSG <b>proprietary</b> steel joist (Dietrich Industries Inc.) spaced at 24" o.c.</li> <li>• resilient metal channels spaced 12" o.c.</li> <li>• 3 5/8" mineral wool or glass fiber batt insulation</li> <li>• 1 layer of 5/8" gypsum board on ceiling side</li> </ul>			
UL L565	<ul style="list-style-type: none"> <li>• 2 layer flooring system (6 types)</li> <li>• trusses spaced a max. 48" o.c.</li> <li>• <b>proprietary</b> pre-fabricated light gauge steel truss systems,               <ol style="list-style-type: none"> <li>1. Ultra-Span by Aegis Metal Framing</li> <li>2. Amkey System by Allied Studco</li> <li>3. Versa-Truss by Dale/Incor</li> <li>4. Strong-Span by Hexaport International Ltd.</li> <li>5. Gus Truss by Nucon Steel Corporation</li> <li>6. TrusSteel by Alpine Engineered Products</li> </ol> </li> <li>• resilient or furring channels spaced 16" o.c.</li> <li>• any thickness mineral wool or glass fiber insulation, optional</li> <li>• 1 layer of 5/8" gypsum board on ceiling side</li> </ul>			

**Floor/Ceiling – Underwriters Laboratories Inc.**

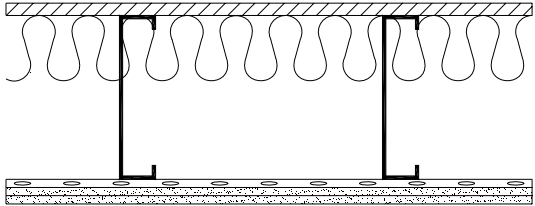
Source	Description	Fire Resistance Rating	Sound Transmission Class	Impact Insulation Class
UL L567	<ul style="list-style-type: none"> <li>• subfloor of ¾" plywood</li> <li>• 10" x 16 MSG <b>proprietary</b> steel joist (Marino\WARE or Rotary Press Systems Inc.) spaced at 16" o.c.</li> <li>• resilient metal channels spaced 16" o.c.</li> <li>• 4" mineral wool or glass fiber insulation friction-fit to underside of plywood</li> <li>• 2 layers of ½" gypsum board on ceiling side</li> </ul> <p>* 77% load restriction</p>			
		* 1 h	-	-

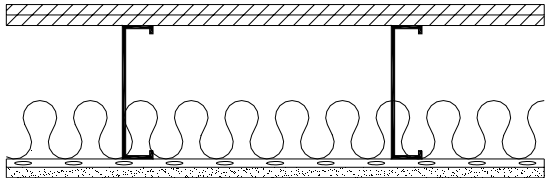
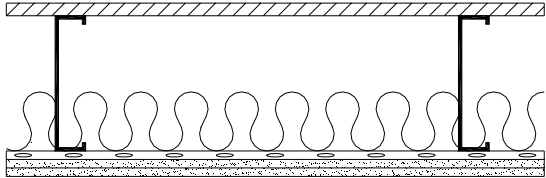
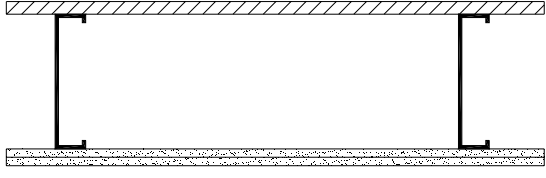
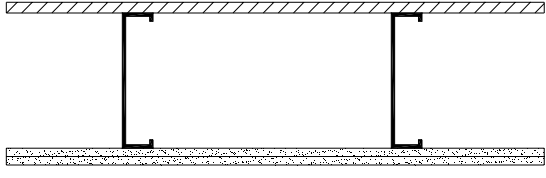

**Floor/Ceiling – Underwriters Laboratories Inc.**

Source	Description	Fire Resistance Rating	Sound Transmission Class	Impact Insulation Class	
UL L568	<ul style="list-style-type: none"> <li>subfloor of 5/8" plywood and finish floor of 5/8" wood structural panels</li> <li>8" x 18 MSG steel joist spaced at 16" o.c.</li> <li>resilient metal channels spaced 16" o.c.</li> <li>3 1/2" mineral wool batt insulation</li> <li>1 layer of 5/8" gypsum board on ceiling side</li> </ul>		45 min	53*	46*
	<ul style="list-style-type: none"> <li>subfloor of 3/4" plywood</li> <li>8" x 18 MSG steel joist spaced at 24" o.c.</li> <li>resilient metal channels spaced 24" o.c.</li> <li>3 1/2" glass fiber batt insulation</li> <li>2 layers of 1/2" gypsum board on ceiling side</li> </ul>		45 min	52*	45*
	<ul style="list-style-type: none"> <li>subfloor of 3/4" plywood</li> <li>8" x 18 MSG steel joist spaced at 24" o.c.</li> <li>2 layers of 1/2" gypsum board on ceiling side</li> </ul>		45 min	<40*	<40*
	<ul style="list-style-type: none"> <li>subfloor of 5/8" plywood</li> <li>8" x 18 MSG steel joist spaced at 16" o.c.</li> <li>2 layers of 1/2" gypsum board on ceiling side</li> </ul>		1 h	<40*	<40*

\* Estimated value as per Warnock (2008)

**Floor/Ceiling – Underwriters Laboratories Inc.**

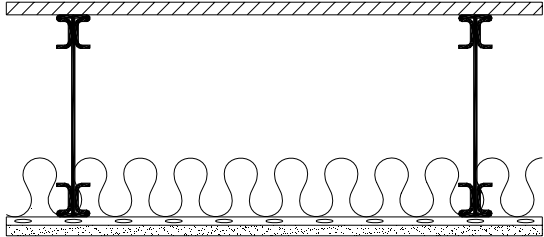
Source	Description	Fire Resistance Rating	Sound Transmission Class	Impact Insulation Class
UL L575	<ul style="list-style-type: none"> <li>• subfloor of ¾" plywood or OSB</li> <li>• 12" deep <b>proprietary</b> steel joist, iSPAN™ licensed by Genesis TP in USA and Canada, with 18 ga material thickness and spaced at 24" o.c.</li> <li>• resilient metal channels spaced 12" o.c.</li> <li>• 3" mineral wool batt insulation</li> <li>• 1 layer of ⅝" gypsum board on ceiling side</li> </ul>		1 h	50
UL L580	<ul style="list-style-type: none"> <li>• subfloor of ¾" plywood</li> <li>• 10" x 16 MSG <b>proprietary</b> steel joist (Marino\WARE) spaced at 16" o.c.</li> <li>• resilient metal channels spaced 16" o.c.</li> <li>• 4" mineral wool insulation friction-fit to underside of plywood</li> <li>• 2 layers of ½" gypsum board on ceiling side</li> </ul> <p>* 70% load restriction</p>			

## Floor/Ceiling – Gypsum Association

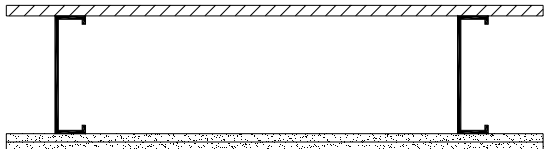
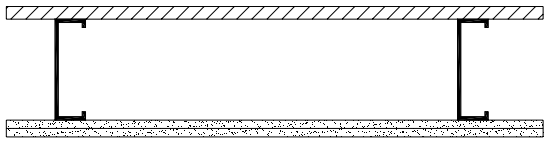
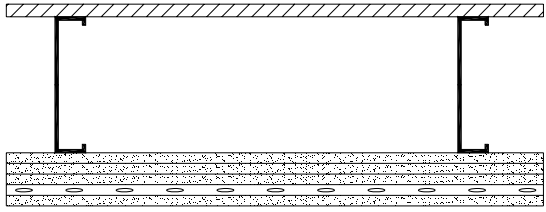
Source	Description	Fire Resistance Rating	Sound Transmission Class	Impact Insulation Class	
GA FC 4502	<ul style="list-style-type: none"> <li>subfloor of 5/8" plywood</li> <li>7" x 18 gage steel joist spaced at 24" o.c.</li> <li>2 layers of 1/2" Type X gypsum board on ceiling side</li> </ul>		1 h	<50*	<40*
GA FC 4503	<ul style="list-style-type: none"> <li>subfloor of 3/4" plywood</li> <li>6" x 16 gage steel joist spaced at 24" o.c.</li> <li>2 layers of 1/2" Type X gypsum board on ceiling side</li> </ul>		1 h	<50*	<40*
GA FC 4750  a) NGC5004021 b) NGC7004068 c) NGC7004069	<ul style="list-style-type: none"> <li>subfloor of 3/4" plywood</li> <li>8" x 16 gage steel joist spaced at 24" o.c.</li> <li>4 layers of 5/8" Type X gypsum board on ceiling side</li> <li>resilient metal channels spaced 24" o.c. and applied perpendicular to joists over third layer of gypsum board</li> </ul>		2 h	48 <sup>a</sup>	37 <sup>b</sup> 60 <sup>c</sup> (CAR-UND)

\* Estimated value as per Warnock (2008)

## Floor/Ceiling – Factory Mutual Research

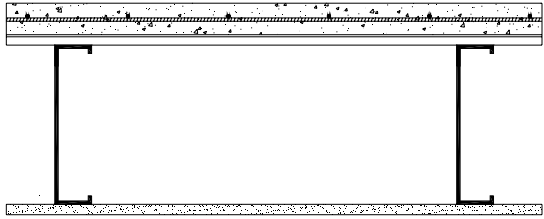
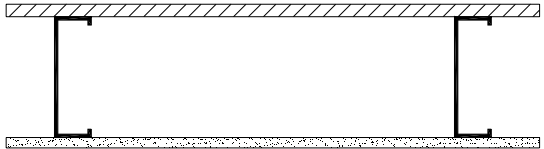
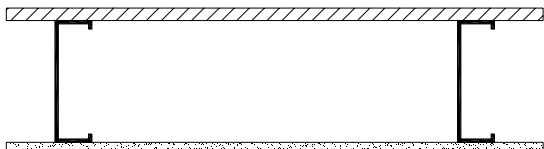
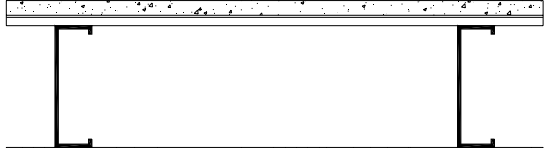
Source	Description	Fire Resistance Rating	Sound Transmission Class	Impact Insulation Class	
FM FC 179	<ul style="list-style-type: none"> <li>• 2 ½" concrete</li> <li>• 6 by 6 welded wire mesh No. 10 SWG steel wire</li> <li>• 28 ga. (0.016" thick) steel deck with 9/16" deep corrugations</li> <li>• 9 ½" x 14 ga. (0.0785" thick) steel joist spaced at 24" o.c.</li> <li>• 1 layer of 5/8" gypsum board on ceiling side</li> </ul>		1 h	-	-
FM FC 184	<ul style="list-style-type: none"> <li>• subfloor of 3/4" plywood</li> <li>• 7 ¼" x 18 ga. (0.050" thick) steel joist spaced at 24" o.c.</li> <li>• 1 layer of 5/8" gypsum board on ceiling side</li> </ul>		45 min	<50*	<40*
FM FC 196	<ul style="list-style-type: none"> <li>• subfloor of 3/4" plywood</li> <li>• 7 ¼" x 18 ga. (0.052" thick) steel joist spaced at 24" o.c.</li> <li>• 2 layers of 1/2" gypsum board on ceiling side</li> </ul>		1 h	<50*	<40*
FM FC 218	<ul style="list-style-type: none"> <li>• 1 ½" Lite-Crete foam concrete</li> <li>• 28 ga. (0.016" thick) steel deck with 9/16" deep corrugations</li> <li>• 7 ¼" x 18 ga. (0.053" thick) steel joist spaced at 24" o.c.</li> <li>• 1 layer of 5/8" gypsum board on ceiling side</li> </ul>		1 h	<50*	<40*

\* Estimated value as per Warnock (2008)

## Floor/Ceiling – Factory Mutual Research

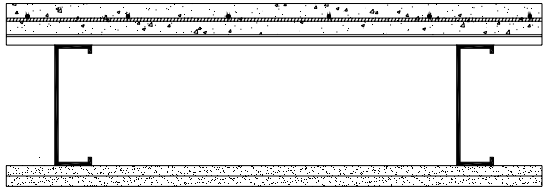
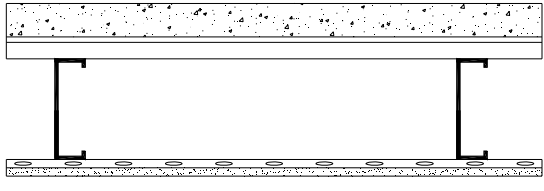
Source	Description	Fire Resistance Rating	Sound Transmission Class	Impact Insulation Class
FM FC 224	<ul style="list-style-type: none"> <li>• 2 ½" concrete</li> <li>• 6 by 6 welded wire mesh No. 10 SWG steel wire</li> <li>• 28 ga. (0.016" thick) steel deck with 9/16" deep corrugations</li> <li>• 7 ¼" x 18 ga. (0.052" thick) steel joist spaced at 24" o.c.</li> <li>• 2 layers of 5/8" gypsum board on ceiling side</li> </ul>			
		2 h	50*	<40*
FM FC 245	<ul style="list-style-type: none"> <li>• 2" lightweight concrete measured from top of the steel deck</li> <li>• 24 ga. (0.026" thick) steel deck with 1 5/16" deep corrugations</li> <li>• 6" x 18 ga. (0.05" thick) steel joist spaced at 24" o.c.</li> <li>• Resilient furring channels spaced at 24" o.c.</li> <li>• 1 layer of ½" gypsum board on ceiling side</li> </ul>			
		1 h	-	-



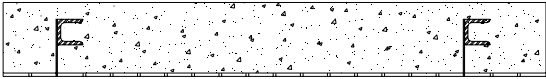
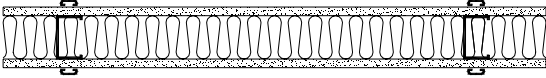
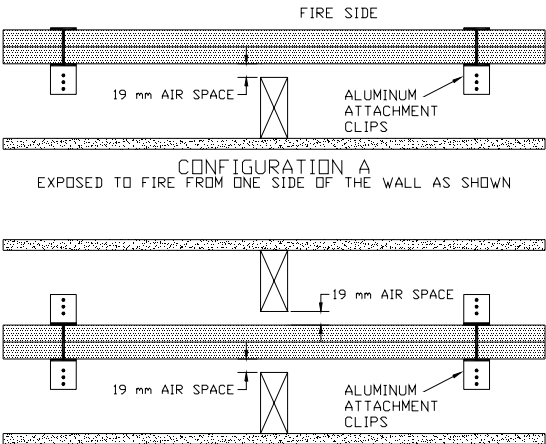
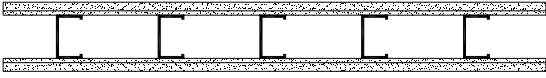

\* Estimated value as per Warnock (2008)

# **NON-LOAD BEARING WALL ASSEMBLIES**

## Non-Load Bearing Walls – Underwriters’ Laboratories of Canada

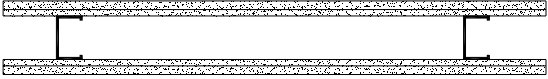
Source	Description	Fire Resistance Rating	Sound Transmission Class
ULC U202	<ul style="list-style-type: none"> <li>paper backed wire fabric</li> <li>38 mm x 38 mm x 5 mm thick steel channel spaced at 600 mm o.c.</li> <li>clips</li> <li>vermiculite concrete</li> </ul>		
		4 h	-
ULC U406 RAL-TL69-42	<ul style="list-style-type: none"> <li>64 mm x 33 mm x 0.5 mm thick steel studs spaced at 600 mm o.c.</li> <li>38 mm mineral wool insulation</li> <li>1 layer 12.7 mm gypsum board each side</li> </ul>		
		1 h	45
ULC W314	<p>Firewall (max. height – 13400 mm)</p> <ul style="list-style-type: none"> <li>51 mm deep x 0.46 mm thick “H” shaped steel studs spaced at 610 mm o.c.</li> <li>2 layers of 25.4 mm thick gypsum wallboard liner panels</li> </ul> <p>Protected Wall (Bearing or Nonbearing Wall)</p> <ul style="list-style-type: none"> <li>38 mm x 89 mm wood studs spaced at 610 mm o.c.</li> <li>1 layer 12.7 mm gypsum board</li> <li>aluminium attachment clips</li> </ul>	 <p>CONFIGURATION A EXPOSED TO FIRE FROM ONE SIDE OF THE WALL AS SHOWN</p> <p>CONFIGURATION B EXPOSED TO FIRE FROM EITHER SIDE</p>	
		2 h	-
ULC W400	<ul style="list-style-type: none"> <li>64 mm x 35 mm x 0.5 mm thick steel studs spaced not less than 150 mm o.c.</li> <li>inner layer 6.4 mm gypsum board each side</li> <li>laminating compound</li> <li>outer layer 12.7 mm gypsum board on each side</li> </ul>		

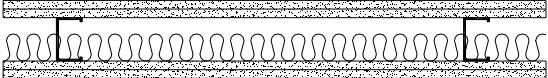

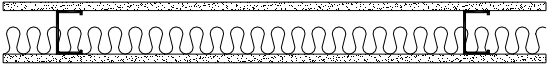
## Non-Load Bearing Walls – Underwriters’ Laboratories of Canada

Source	Description	Fire Resistance Rating	Sound Transmission Class
ULC W402	<ul style="list-style-type: none"> <li>64 mm x 35 mm x 0.5 mm thick steel studs spaced not less than 150 mm o.c.</li> <li>inner layer 9.5 mm gypsum board each side</li> <li>laminating compound</li> <li>outer layer 12.7 mm or 15.9 mm gypsum board on each side</li> </ul>		<p>1 h</p> <p>&lt;45* (G 12.7mm)</p>
ULC W404  RAL-TL75-73	<ul style="list-style-type: none"> <li>64 mm x 35 mm x 0.5 mm thick steel studs spaced not less than 150 mm o.c.</li> <li>inner layer 12.7 mm or 15.9 mm gypsum board each side</li> <li>optional adhesive</li> <li>outer layer 15.9 mm gypsum board on each side</li> </ul>		<p>2 h</p> <p>47 (G 15.9mm)</p>
ULC W406  a) CK654-40 b) USG800502 c) SA860932	<ul style="list-style-type: none"> <li>64 mm x 32 mm x 0.5 mm thick steel studs spaced 600 mm o.c.</li> <li>optional 38 mm mineral wool insulation</li> <li>2 layers 12.7 mm gypsum board each side</li> <li>laminating adhesive between inner and outer layer</li> </ul>		<p>2 h</p> <p>54<sup>a</sup> (RFB 40mm) 53<sup>b</sup> (RFB 40mm) 52<sup>c</sup> (RFB 40mm)</p>
ULC W407  RAL-TL92-239	<ul style="list-style-type: none"> <li>92 mm x 35 mm x 0.5 mm thick steel studs spaced 600 mm o.c.</li> <li>1 layer of 15.9 mm gypsum board on each side</li> </ul>		<p>1 h</p> <p>39</p>
ULC W408  RAL-TL69-42	<ul style="list-style-type: none"> <li>64 mm x 35 mm x 0.5 mm thick steel studs spaced 600 mm o.c.</li> <li>38 mm mineral wool insulation</li> <li>1 layer of 12.7 mm gypsum board on each side</li> </ul>		<p>1 h</p> <p>45</p>

\* Estimated value as per Warnock (2008)



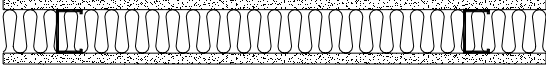

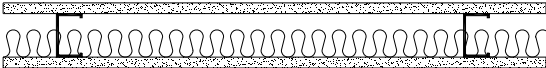
## Non-Load Bearing Walls – Underwriters’ Laboratories of Canada

Source	Description	Fire Resistance Rating	Sound Transmission Class
ULC W409	<ul style="list-style-type: none"> <li>63 mm x 31 mm x 0.6 mm thick steel studs spaced 600 mm o.c.</li> <li>70 mm glass fibre insulation</li> <li>1 layer of 15.9 mm gypsum board on each side</li> </ul> <p>** 45 min rating without insulation</p>		
		1 h ** 45 min	49*
ULC W410	<ul style="list-style-type: none"> <li>41 mm x 32 mm x 0.5 mm thick steel studs spaced 600 mm o.c.</li> <li>inner layer of 9.5 mm gypsum board on each side</li> <li>outer layer of 12.7mm or 15.9 mm gypsum board on each side</li> </ul>		
		1 h	27* (G 12.7mm) 29* (G 15.9mm)
ULC W411	<ul style="list-style-type: none"> <li>67 mm x 17 mm x 0.6 mm thick H section vented studs spaced at 600 mm o.c.</li> <li>19 mm “ultrawall” panels each side</li> </ul>		
		1 h	39*
ULC W412 a) RAL-TL69-42 b) USG 800506	<ul style="list-style-type: none"> <li>64 mm x 35 mm x 0.5 mm thick steel studs spaced 600 mm o.c.</li> <li>38 mm mineral wool insulation</li> <li>1 layer of 12.7 mm or 15.9 mm gypsum board on each side</li> </ul>		
		1 h	45 <sup>a</sup> (G 12.7mm) 46 <sup>b</sup> (G 15.9mm)

\* Estimated value as per Warnock (2008)

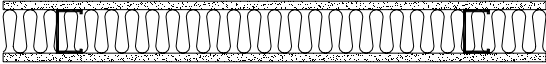
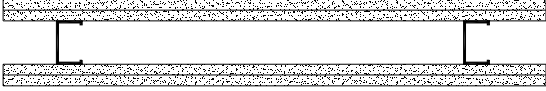
## Non-Load Bearing Walls – Underwriters’ Laboratories of Canada

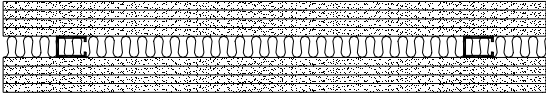
Source	Description	Fire Resistance Rating	Sound Transmission Class
ULC W413	<ul style="list-style-type: none"> <li>64 mm x 35 mm x 0.5 mm thick steel studs spaced 600 mm o.c.</li> <li>70 mm glass fibre insulation</li> <li>1 layer of 12.7 mm gypsum board on each side</li> </ul>		
		45 min	47*
ULC W414	<ul style="list-style-type: none"> <li>63 mm x 31 mm x 0.6 mm thick steel channel spaced 600 mm o.c.</li> <li>2 layers 12.7 mm or 15.9 mm gypsum board each side</li> <li>outer layer laminated to inner layer with laminating compound</li> </ul>		
		2 h	44* (G 12.7mm) 47* (G 15.9mm)
ULC W415 NRC TL-92-376	<ul style="list-style-type: none"> <li>92 mm x 35 mm x 0.5 mm thick steel studs spaced 600 mm o.c.</li> <li>1 layer of 15.9 mm gypsum board on each side</li> </ul>		
		1 h	38
ULC W417 a) SA 830113 b) SA 830112	<ul style="list-style-type: none"> <li>41 mm x 31 mm x 0.5 mm thick steel studs spaced 600 mm o.c.</li> <li>optional 38 mm mineral wool insulation</li> <li>4 hours - 4 layers of 12.7 mm gypsum board on each side</li> <li>3 hours – 3 layers of 12.7 mm gypsum board on each side</li> </ul>		
		4 h 3 h	62 <sup>a</sup> (RFB 40mm) 59 <sup>b</sup> (RFB 40mm)

\* Estimated value as per Warnock (2008)

## Non-Load Bearing Walls – Underwriters’ Laboratories of Canada

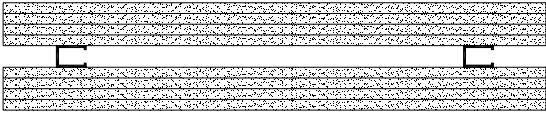
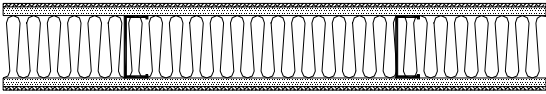
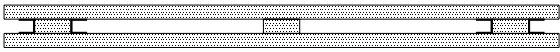
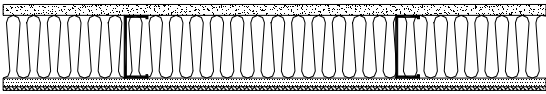
Source	Description	Fire Resistance Rating	Sound Transmission Class
ULC W418	<ul style="list-style-type: none"> <li>41 mm x 32 mm x 0.53 mm thick steel studs spaced 600 mm o.c.</li> <li>4 hours - 4 layers of 12.7 mm or 15.9 mm gypsum board on each side</li> <li>3 hours – 3 layers of 12.7 mm or 15.9 mm gypsum board on each side</li> </ul>		
		4 h 3 h	50* (G 12.7mm) 46* (G 15.9mm)
ULC W419	<ul style="list-style-type: none"> <li>92 mm x 32 mm x 0.5 mm thick steel studs spaced 400 mm o.c.</li> <li>90 mm mineral wool insulation</li> <li>inner layer of 12.7 mm tile backer board each side</li> <li>outer layer of 5.2 mm ceramic tile each side, joints filled with wall grout</li> </ul>		
		1 h	54*
ULC W421	<ul style="list-style-type: none"> <li>38 mm x 40 mm x 0.6 mm channel studs spaced 1220 mm o.c.</li> <li>1 layer 38 mm thick x 1.22 m wide mineral and fibre board each side</li> <li>38 mm thick x 101.6 mm wide mineral and fibre board backing strips</li> </ul>		
		2 h	-
ULC W423	<ul style="list-style-type: none"> <li>92 mm x 32 mm x 0.5 mm thick steel studs spaced 400 mm o.c.</li> <li>90 mm mineral wool insulation</li> <li>inner layer of 12.7 mm tile backer board on one side, designated “Durock”</li> <li>outer layer of 5.2 mm ceramic tile, joints filled with wall grout</li> <li>1 layer of 12.7 mm or 15.9 mm gypsum board on one side.</li> </ul>		
		1 h	51* (G 12.7mm) 52* (G 15.9mm)

\* Estimated value as per Warnock (2008)

## Non-Load Bearing Walls – Underwriters’ Laboratories of Canada

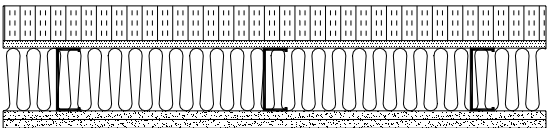
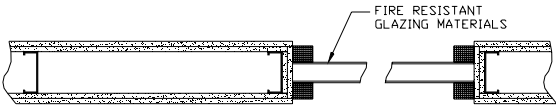
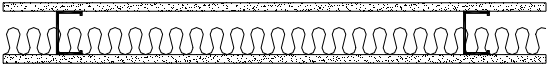
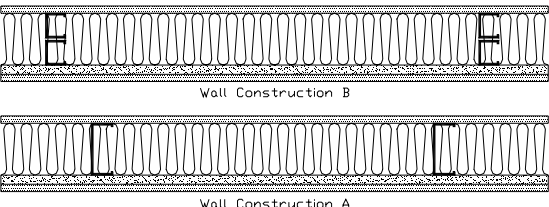
Source	Description	Fire Resistance Rating	Sound Transmission Class
ULC W425	<ul style="list-style-type: none"> <li>92 mm x 35 mm x 0.9 mm thick steel studs spaced 305 mm o.c.</li> <li>90 mm glass fibre insulation</li> <li>38 mm x 12.7 mm x 1.2 mm thick channel bracing inserted in the knockouts and supported by angles</li> <li>0.05 mm clear polyethylene</li> <li>2 layers of 12.7 mm gypsum board on one side</li> <li>see ULC description for exterior insulation and stucco finish details</li> </ul>		
		2 h	-
ULC W426	<ul style="list-style-type: none"> <li>102 mm x 32 mm x 1.0 mm thick steel studs spaced 600 mm o.c.</li> <li>2 layers of 12.7 mm gypsum board on each side</li> <li>fire resistant glazing materials</li> </ul>		
		1 h	-
ULC W433 RAL-TL69-42	<ul style="list-style-type: none"> <li>64 mm x 35 mm x 0.5 mm thick steel studs spaced 600 mm o.c.</li> <li>38 mm mineral wool insulation designated “Acoustical Fire Batts”</li> <li>1 layer of 12.7 mm gypsum board on each side</li> </ul>		
		1 h	45
ULC W436	<ul style="list-style-type: none"> <li>Wall A – 90 mm x 35 mm x 0.62 mm thick steel studs spaced at 600 mm o.c.</li> <li>89 mm mineral wool insulation</li> <li>1 layer of 12.7 mm or 15.9 mm gypsum board on one side</li> <li>1 layer of 12.7 mm reinforced cement board, designated “PanaRoc” on each side</li> </ul>		
		1 h *see ULC listing for Wall B design	51* (Wall A, G 12.7mm) 54* (Wall B, G 15.9mm)

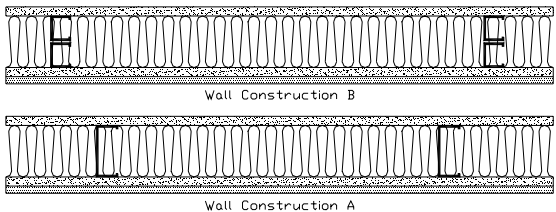
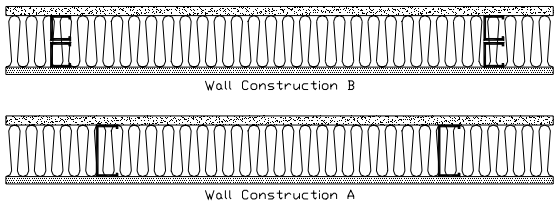
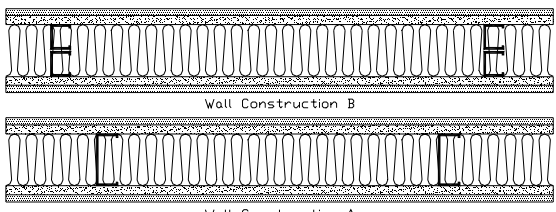
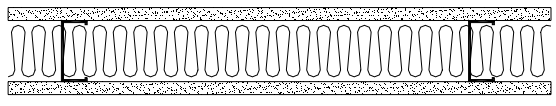

\* Estimated value as per Warnock (2008)

## Non-Load Bearing Walls – Underwriters’ Laboratories of Canada

Source	Description	Fire Resistance Rating	Sound Transmission Class	
ULC W437	<ul style="list-style-type: none"> <li>Wall A – 90 mm x 35 mm x 0.62 mm thick steel studs spaced at 600 mm o.c.</li> <li>89 mm mineral wool insulation</li> <li>1 layer of 12.7 mm or 15.9 mm gypsum board on each side</li> <li>1 layer of 12.7 mm reinforced cement board, designated “PanaRoc” on one side</li> </ul>	 <p>Wall Construction B</p> <p>Wall Construction A</p>	<p>1 h</p> <p>*see ULC listing for Wall B design</p>	<p>52* (Wall A, G 12.7mm)</p> <p>54* (Wall A, G 15.9mm)</p> <p>55* (Wall B, G 12.7mm)</p> <p>57* (Wall B, G 15.9mm)</p>
ULC W438	<ul style="list-style-type: none"> <li>Wall A – 90 mm x 32 mm x 0.62 mm thick steel studs spaced at 600 mm o.c.</li> <li>89 mm mineral wool insulation</li> <li>1 layer of 15.9 mm gypsum board on one side</li> <li>1 layer of 12.7 mm reinforced cement board, designated “PanaRoc” on other side</li> </ul>	 <p>Wall Construction B</p> <p>Wall Construction A</p>	<p>1 h</p> <p>*see ULC listing for Wall B design</p>	<p>49* (Wall A)</p> <p>55* (Wall B)</p>
ULC W439	<ul style="list-style-type: none"> <li>Wall A – 90 mm x 32 mm x 0.62 mm thick steel studs spaced at 600 mm o.c.</li> <li>89 mm mineral wool insulation</li> <li>1 layer of 12.7 mm or 15.9 mm gypsum board on each side</li> <li>1 layer of 12.7 mm reinforced cement board, designated “PanaRoc” on each side</li> </ul>	 <p>Wall Construction B</p> <p>Wall Construction A</p>	<p>2 h</p> <p>*see ULC listing for Wall B design</p>	<p>55* (Wall A, G 12.7mm)</p> <p>56* (Wall A, G 15.9mm)</p> <p>55* (Wall B, G 12.7mm)</p> <p>57* (Wall B, G 15.9mm)</p>
ULC W440 USG910617	<ul style="list-style-type: none"> <li>89 mm x 32 mm x 0.5 mm thick steel studs spaced at 610 mm o.c.</li> <li>76 mm mineral wool insulation</li> <li>1 layer of 19.1 mm gypsum board on each side</li> </ul>		<p>2 h</p>	<p>50</p>

\* Estimated value as per Warnock (2008)

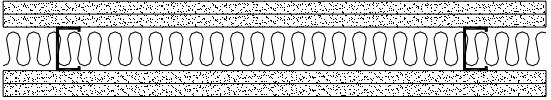
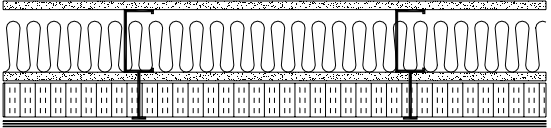
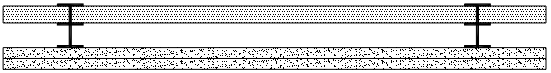
## Non-Load Bearing Walls – Underwriters’ Laboratories of Canada

Source	Description	Fire Resistance Rating	Sound Transmission Class
ULC W441 a) SA910507 b) USG910907	<ul style="list-style-type: none"> <li>64 mm x 32 mm x 0.5 mm thick steel studs spaced at 610 mm o.c.</li> <li>50 mm mineral wool insulation</li> <li>2 layers of 19.1 mm gypsum board on each side</li> </ul>		
		4 h	56 <sup>a &amp; b</sup>
ULC W442	See ULC listing for full description  * Fire exposure from exterior side ** Fire exposure from interior side		
		1 h * 1-½ h **	-
ULC W446	System A		
	<ul style="list-style-type: none"> <li>64 mm x 38 mm x 0.53 mm thick "I" steel studs with 19 mm x 57 mm high holding tabs spaced at 610 mm o.c.</li> <li>25.4 mm gypsum board on one side</li> <li>2 layers of 12.7 mm or 15.9 mm gypsum board on other side</li> </ul>	2 h	39* (G 12.7mm) 41* (G 15.9mm)
	System B		
	<ul style="list-style-type: none"> <li>64 mm x 38 mm x 0.53 mm thick "I" steel studs with 19 mm x 57 mm high holding tabs spaced at 610 mm o.c.</li> <li>inner layer of 25.4 mm gypsum board on one side</li> <li>1 layer of 12.7 mm or 15.9 mm gypsum board on each side</li> </ul>	2 h	-

\* Estimated value as per Warnock (2008)

## Non-Load Bearing Walls – Underwriters’ Laboratories of Canada

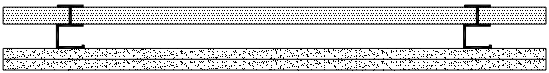
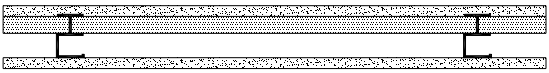
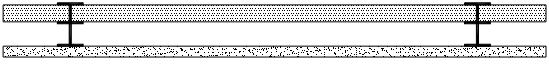
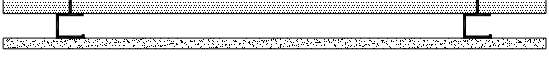
Source	Description	Fire Resistance Rating	Sound Transmission Class
ULC W446 (cont.)	<b>System C</b> <ul style="list-style-type: none"> <li>• 64 mm x 38 mm x 0.53 mm thick “C-T” shaped steel studs spaced at 610 mm o.c.</li> <li>• 1 layer 25.4 mm gypsum board on one side</li> <li>• 2 layers of 12.7 mm or 15.9 mm gypsum board on other side</li> </ul>		-
	<b>System D</b> <ul style="list-style-type: none"> <li>• 64 mm x 38 mm x 0.53 mm thick “C-T” shaped steel studs spaced at 610 mm o.c.</li> <li>• inner layer of 25.4 mm gypsum board on one side, with 12.7 mm or 15.9 mm gypsum board outer layer</li> <li>• 1 layer of 12.7 mm or 15.9 mm gypsum board on other side</li> </ul>		-
	<b>System E</b> <ul style="list-style-type: none"> <li>• 64 mm x 38 mm x 0.53 mm thick “I” steel studs with 19 mm x 57 mm high holding tabs spaced at 610 mm o.c.</li> <li>• 1 layer 25.4 mm gypsum board on one side</li> <li>• 1 layer of 15.9 mm gypsum board on other side</li> </ul>		-
	<b>System F</b> <ul style="list-style-type: none"> <li>• 64 mm x 38 mm x 0.53 mm thick “C-T” shaped steel studs spaced at 610 mm o.c.</li> <li>• 1 layer 25.4 mm gypsum board on one side</li> <li>• 1 layer of 15.9 mm gypsum board on other side</li> </ul>		-
		2 h	-
		2 h	-
		1 h	-
		1 h	-

## Non-Load Bearing Walls – Underwriters’ Laboratories of Canada

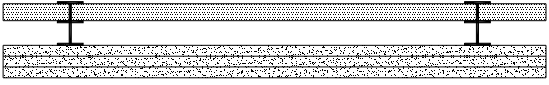
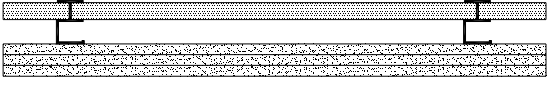
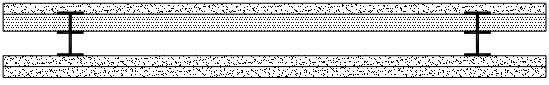
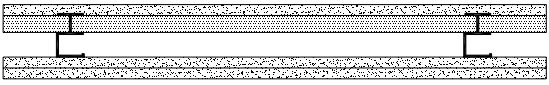

Source	Description	Fire Resistance Rating	Sound Transmission Class
ULC W446 (cont.)	<b>System G</b> <ul style="list-style-type: none"> <li>• 64 mm x 38 mm x 0.53 mm thick “I” steel studs with 19 mm x 57 mm high holding tabs spaced at 610 mm o.c.</li> <li>• 1 layer 25.4 mm gypsum board on one side</li> <li>• 3 layers of 15.9 mm gypsum board on other side</li> </ul>		
	<b>System H</b> <ul style="list-style-type: none"> <li>• 64 mm x 38 mm x 0.53 mm thick “C-T” shaped steel studs spaced at 610 mm o.c.</li> <li>• 1 layer 25.4 mm gypsum board on one side</li> <li>• 3 layers of 15.9 mm gypsum board on other side</li> </ul>		
	<b>System I</b> <ul style="list-style-type: none"> <li>• 64 mm x 38 mm x 0.53 mm thick “I” steel studs with 19 mm x 57 mm high holding tabs spaced at 610 mm o.c.</li> <li>• inner layer of 25.4 mm gypsum board on one side, with 15.9 mm gypsum board outer layer</li> <li>• 2 layers of 15.9 mm gypsum board on other side</li> </ul>		
	<b>System J</b> <ul style="list-style-type: none"> <li>• 64 mm x 38 mm x 0.53 mm thick “C-T” shaped steel studs spaced at 610 mm o.c.</li> <li>• inner layer of 25.4 mm gypsum board on one side, with 15.9 mm gypsum board outer layer</li> <li>• 2 layers of 15.9 mm gypsum board on other side</li> </ul>		
		3 h	-
		3 h	-
		3 h	-

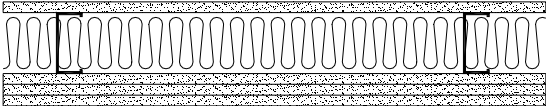
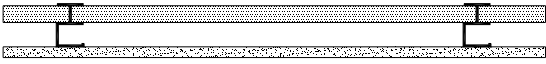
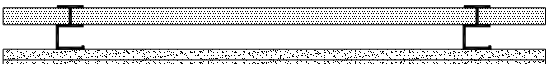
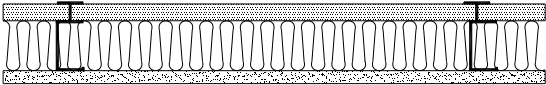

## Non-Load Bearing Walls – Underwriters’ Laboratories of Canada

Source	Description	Fire Resistance Rating	Sound Transmission Class
ULC W451	<ul style="list-style-type: none"> <li>89 mm x 32 mm x 0.46 mm thick steel studs spaced at 610 mm o.c.</li> <li>optional mineral fiber insulation produced from rock, slag or glass</li> <li>1 layer of 15.9 mm gypsum board on one side</li> <li>3 layers of 15.9 mm gypsum board on other side</li> </ul>		
		2 h	-
ULC W452	<b>System A</b> <ul style="list-style-type: none"> <li>64 mm deep x 0.46 mm thick “C-H” shaped steel studs spaced at 610 mm o.c.</li> <li>1 layer 25.4 mm gypsum liner board panels on one side</li> <li>1 layer of 15.9 mm gypsum wallboard on other side</li> </ul>		
	1 h	-	
	<b>System B</b> <ul style="list-style-type: none"> <li>64 mm deep x 0.46 mm thick “C-H” shaped steel studs spaced at 610 mm o.c.</li> <li>1 layer 25.4 mm gypsum liner board panels on one side</li> <li>2 layers of 12.7 mm or 15.9 mm gypsum wallboard on other side</li> </ul>		
	2 h	-	
	<b>System C</b> <ul style="list-style-type: none"> <li>102 mm deep x 0.46 mm thick “C-H” shaped steel studs spaced at 610 mm o.c.</li> <li>75 mm min. mineral wool batts</li> <li>1 layer 25.4 mm gypsum liner board panels on one side</li> <li>1 layer of 19.1 mm gypsum wallboard on other side</li> </ul>		
	2 h	-	

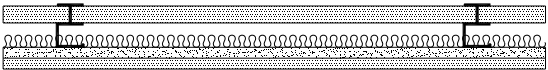

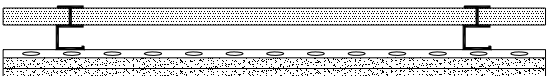
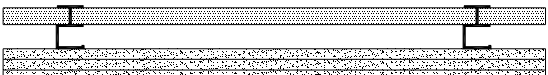
**Non-Load Bearing Walls – Underwriters’ Laboratories of Canada**

Source	Description	Fire Resistance Rating	Sound Transmission Class
ULC W452 (cont.)	<p><b>System D</b></p> <ul style="list-style-type: none"> <li>• 64 mm deep x 0.84 mm thick “C-H” shaped steel studs spaced at 610 mm o.c.</li> <li>• 1 layer 25.4 mm gypsum liner board panels on one side</li> <li>• 38 mm min. mineral wool batts</li> <li>• 1 layer of 15.9 mm gypsum wallboard and 1 layer of 12.7 mm or 15.9 mm mineral and fibre board designated “Durock” on other side</li> </ul>		
		2 h	-
	<p><b>System E</b></p> <ul style="list-style-type: none"> <li>• 64 mm deep x 0.46 mm thick “C-H” shaped steel studs spaced at 610 mm o.c.</li> <li>• 1 layer 25.4 mm gypsum liner board panels on one side</li> <li>• 1 layer of 12.7 mm or 15.9 mm gypsum wallboard on each side</li> </ul>		
		2 h	-
	<p><b>System F</b></p> <ul style="list-style-type: none"> <li>• 64 mm deep x 0.46 mm thick “C-H” shaped steel studs spaced at 610 mm o.c.</li> <li>• 1 layer 25.4 mm gypsum liner board panels on one side</li> <li>• furring channels spaced at 610 mm o.c.</li> <li>• 2 layers of 12.7 mm or 15.9 mm gypsum wallboard on other side</li> </ul>		
		2 h	-
	<p><b>System G</b></p> <ul style="list-style-type: none"> <li>• 64 mm deep x 0.46 mm thick “C-H” shaped steel studs spaced at 610 mm o.c.</li> <li>• 1 layer 25.4 mm gypsum liner board panels on one side</li> <li>• 3 layers of 15.9 mm gypsum wallboard on other side</li> </ul>		
		3 h	-

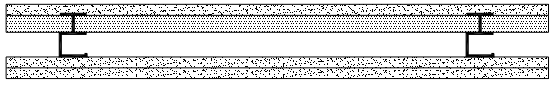
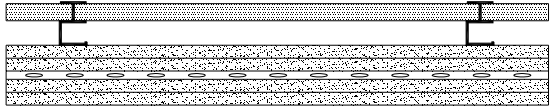
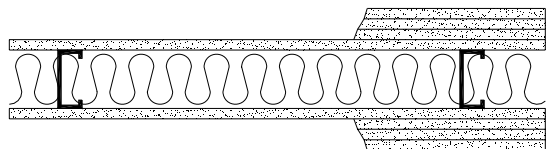
## Non-Load Bearing Walls – Underwriters’ Laboratories of Canada

Source	Description	Fire Resistance Rating	Sound Transmission Class			
ULC W452 (cont.)	<b>System H</b> <ul style="list-style-type: none"> <li>• 64 mm deep x 0.46 mm thick “C-H” shaped steel studs spaced at 610 mm o.c.</li> <li>• 1 layer 25.4 mm gypsum liner board panels and 1 layer of 15.9 mm gypsum wallboard on one side</li> <li>• 2 layers of 15.9 mm gypsum wallboard on other side</li> </ul>		3 h	-		
	<b>System I</b> <ul style="list-style-type: none"> <li>• 64 mm deep x 0.46 mm thick “C-H” shaped steel studs spaced at 610 mm o.c.</li> <li>• 1 layer 25.4 mm gypsum liner board panels on one side</li> <li>• 4 layers of 19.1 mm gypsum wallboard on other side</li> <li>• furring channels spaced at 610 mm o.c. and applied over second layer</li> </ul>		4 h	-		
<b>ULC W453</b>  a) SA870717 b) SA860620 c) RAL-TL90-166 d) USG860808 e) USG910617 f) SA830112 g) SA830113 h) USG910907	<ul style="list-style-type: none"> <li>• min. 0.46mm thick steel studs spaced at 610 mm o.c.</li> <li>• mineral wool insulation optional except where required as noted by asterisk and described below</li> <li>• stud depth, drywall layers, drywall thickness, and corresponding rating as shown</li> </ul> <p>* 38 mm mineral wool insulation                      ** 76 mm mineral wool insulation                      *** 51 mm mineral wool insulation</p>		1 h	-		
		# Layer & Size	Stud Depth	49 <sup>a</sup> (RFB 76) 51 <sup>b&amp;c</sup> (RFB 89) 40 <sup>d</sup> (NI)  50 <sup>e</sup> 59 <sup>f</sup> (RFB 38)  62 <sup>g</sup> (RFB 38) 56 <sup>h</sup>		
		1 h	1-15.9			89
		1 h	1-12.7			64*
		1 h	1-19.1			41
		2 h	2-12.7			41
		2 h	2-15.9			41
		2 h	1-19.1			89**
		3 h	3-12.7			41
		3 h	2-19.1			41
3 h	3-15.9	41				
4 h	4-15.9	41				
4 h	4-12.7	41				
4 h	2-19.1	64***				

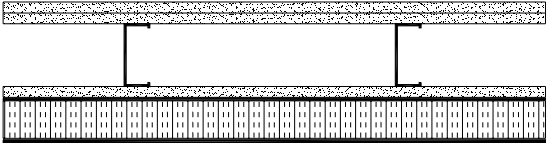
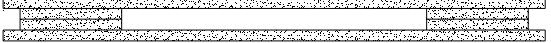
## Non-Load Bearing Walls – Underwriters’ Laboratories of Canada

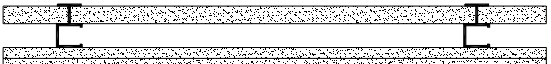

Source	Description	Fire Resistance Rating	Sound Transmission Class
ULC W456	<ul style="list-style-type: none"> <li>• 92 mm x 40 mm x 0.92 mm thick steel studs spaced at 406 mm o.c.</li> <li>• inner 2 layers of 15.9 mm Type X gypsum board</li> <li>• 1 layer of 15.9 mm gypsum board on other side</li> <li>• 150 mm max. thick polystyrene insulation boards</li> <li>• components in exterior wall insulation and finish system by Durabond Products Ltd.</li> </ul>		
		2 h	-
ULC W502	<ul style="list-style-type: none"> <li>• two or three layers of 12.7 mm or 15.9 mm thick, 150 mm wide wallboard ribs spaced at 600 mm o.c.</li> <li>• 1 layer 15.9 mm gypsum board on each side</li> </ul>		
		1 h	-
ULC W506	<ul style="list-style-type: none"> <li>• 64 mm x 35 mm x 0.5 mm thick steel “C-H” shaped studs spaced at 600 mm o.c.</li> <li>• 1 layer 25 mm gypsum board on one side</li> <li>• 2 layers 12.7 mm gypsum board on other side</li> </ul>		
		2 h	-
ULC W507	<ul style="list-style-type: none"> <li>• 64 mm x 35 mm x 0.5 mm thick steel “C-H” shaped studs spaced at 600 mm o.c.</li> <li>• 1 layer 25 mm gypsum board on one side</li> <li>• 2 layers 15.9 mm gypsum board on other side</li> </ul>		
		2 h	-

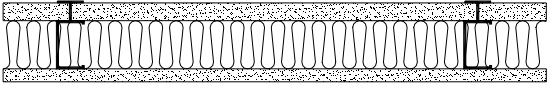
## Non-Load Bearing Walls – Underwriters’ Laboratories of Canada

Source	Description	Fire Resistance Rating	Sound Transmission Class
ULC W508  USG910913	<ul style="list-style-type: none"> <li>• 100 mm x 38 mm x 0.5 mm thick steel “C-H” shaped studs spaced at 610 mm o.c.</li> <li>• 76 mm mineral wool insulation</li> <li>• 1 layer 25.4 mm gypsum board on one side</li> <li>• 1 layer 19.1 mm gypsum board on other side</li> </ul>		
		2 h	52

**NOTE:** ULC Certification Bulletin No. 2003-08 (dated August 21, 2003) provides an official ULC permission for ULC listed and package labelled mineral fibre building insulation (processed from rock, slag and glass only) to be used in ULC non-load bearing wall assembly designs consisting of gypsum wallboard and steel or wood studs with a fire resistance rating not exceeding 2 hours when illustrated without insulation, without detracting from the rating assigned to the assembly.

## Non-Load Bearing Walls – National Research Council of Canada

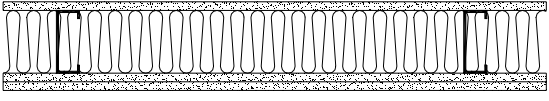
Source	Description	Fire Endurance	Sound Transmission Class
NRCC IR-674 F03 F05  USG840817	<ul style="list-style-type: none"> <li>90 mm x 30 mm x 0.46 mm thick steel studs spaced at 600 mm o.c.</li> <li>2 layers 12.7 mm gypsum board on each side</li> </ul> NOTE: Density of gypsum board varies between two tests; F03=7.35kg/m <sup>2</sup> F05=7.80 kg/m <sup>2</sup>		
		F03 = 63 min F05 = 69 min	50
NRCC IR-675 F07  TLA-02-013a	<ul style="list-style-type: none"> <li>90 mm x 30 mm x 0.46 mm thick steel studs spaced at 600 mm o.c.</li> <li>1 layer 12.7 mm gypsum board on one side</li> <li>2 layers 12.7 mm gypsum board on other side</li> </ul>		
		65 min	41
NRCC IR-675 F09 F10 F10B F11  a) NRC TL-92-411 b) TL-93-027	<ul style="list-style-type: none"> <li>90 mm x 30 mm x 0.46 mm thick steel studs spaced at 600 mm o.c.</li> <li>1 layer 12.7 mm gypsum board on one side</li> <li>2 layers 12.7 mm gypsum board on other side</li> <li>90 mm thick insulation as follows:</li> </ul> F09 - glass fibre F10 - 584 mm wide mineral fibre F10B - 615 mm wide mineral fibre F11 - cellulose		
		F09 = 65 min F10 = 60 min F10B = 100 min F11 = 62 min	52 <sup>a</sup> 52* 52* 53 <sup>b</sup>

\* Estimated value as per Warnock (2008)

### References:

Sultan, M.A., Lougheed, G.D., Denham, E.M.A., Monette, R.C. and MacLaurin, J.W., *Temperature Measurements in Full-Scale Fire Resistance Tests on Non-Insulated Regular Gypsum Board Wall Assemblies*, IRC Internal Report No. 674, National Research Council of Canada, Ottawa, Ontario, Canada, December 1994.

Sultan, M.A., MacLaurin, J.W., Denham, E.M.A. and Monette, R.C., *Temperature Measurements in Full-Scale Insulated and Non-Insulated (1x2) Gypsum Board Protected Wall Assemblies with Steel Studs*, IRC Internal Report No. 675, National Research Council of Canada, Ottawa, Ontario, Canada, December 1994.

\* Warnock, A.C.C., *Estimation of Sound Transmission Class and Impact Insulation Class Rating for Steel Framed Assemblies*, Report No. B3436.1, Institute for Research in Construction, National Research Council of Canada, Ottawa, Ontario, Canada, December 2005.

**Non-Load Bearing Walls – Underwriters Laboratories Inc.**

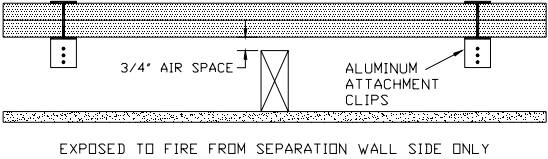
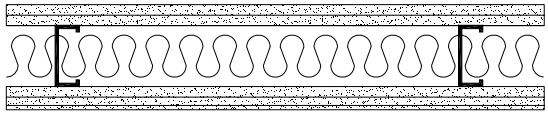
Source	Description	Fire Resistance Rating	Sound Transmission Class
UL U336	<p>Firewall (max. height – 66 feet)</p> <ul style="list-style-type: none"> <li>• 2" deep x 25 MSG "H" shaped steel studs spaced at 24" o.c.</li> <li>• 2 layers of 1" thick gypsum wallboard liner panels</li> </ul> <p>Protected Wall (Bearing or Nonbearing Wall)</p> <ul style="list-style-type: none"> <li>• 2" x 4" wood studs spaced at 24" o.c.</li> <li>• 1 layer 1/2" gypsum board</li> <li>• aluminium attachment clips</li> </ul>		<p>2 h</p> <p>-</p>
UL U403	<ul style="list-style-type: none"> <li>• 3 5/8" x 1 1/4" x 25 gauge steel studs spaced at 24" o.c.</li> <li>• optional mineral wool or glass fiber insulation</li> <li>• 2 layers 5/8" thick gypsum board on one side</li> <li>• 1 layer 5/8", 1 layer 1/2" and 1 layer 1/4" or 3/8" thick gypsum board on other side</li> </ul>		<p>2 h</p> <p>58*</p>

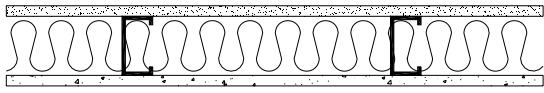
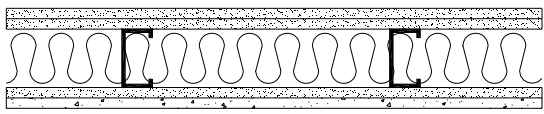
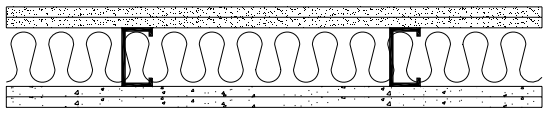
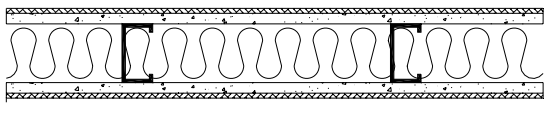

\* Estimated value as per Warnock (2008)

**Non-Load Bearing Walls – Underwriters Laboratories Inc.**

Source	Description	Fire Resistance Rating	Sound Transmission Class
UL U404	<ul style="list-style-type: none"> <li>• 3 1/2" x 20 MSG steel studs spaced at 16" o.c.</li> <li>• 3" mineral wool insulation</li> <li>• 1 layer 1/2" or 5/8" cementitious board on one side</li> <li>• 1 layer 5/8" thick gypsum board on other side</li> </ul>		
	<p style="text-align: center;">1 h</p>	<p style="text-align: center;">-</p>	
	<ul style="list-style-type: none"> <li>• 3 1/2" x 20 MSG steel studs spaced at 16" o.c.</li> <li>• 3" mineral wool insulation</li> <li>• 2 layers 5/8" gypsum board on one side</li> <li>• inner layer of 5/8" thick gypsum, outer layer of 1/2" or 5/8" cementitious board on other side</li> </ul>	 <p style="text-align: center;">Configuration A</p>	
<p style="text-align: center;">2 h</p>	<p style="text-align: center;">-</p>		
<ul style="list-style-type: none"> <li>• 3 1/2" x 20 MSG steel studs spaced at 16" o.c.</li> <li>• 3" mineral wool insulation</li> <li>• 2 layers 1/2" or 5/8" cementitious board on one side</li> <li>• 2 layers 5/8" thick gypsum board on other side</li> </ul>	 <p style="text-align: center;">Configuration B</p>		
<p style="text-align: center;">2 h</p>	<p style="text-align: center;">-</p>		
UL U407  USG 840321	<ul style="list-style-type: none"> <li>• 3 1/2" x 20 MSG steel studs spaced at 16" o.c.</li> <li>• 3" mineral wool insulation</li> <li>• 5/8" cementitious board, ceramic tiles and exterior finish on either side</li> </ul>		
<p style="text-align: center;">1 h</p>	<p style="text-align: center;">48</p>		



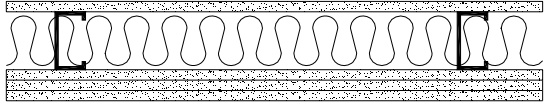
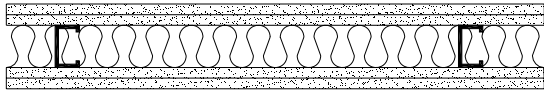
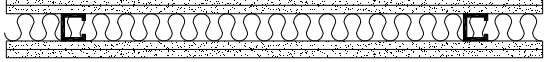
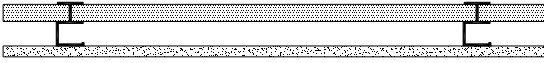

**Non-Load Bearing Walls – Underwriters Laboratories Inc.**

Source	Description	Fire Resistance Rating	Sound Transmission Class	
UL U408	<ul style="list-style-type: none"> <li>• 3 1/2" x 1 1/4" x 25 MSG steel studs spaced at 24" o.c.</li> <li>• optional glass fibre or mineral wool insulation</li> <li>• 1 layer 5/8" gypsum board on one side</li> <li>• 3 layers 5/8" gypsum board on other side</li> </ul>		2 h	-
UL U411 NRC TL-93-037	<ul style="list-style-type: none"> <li>• 2 1/2" x 1 1/4" x 25 MSG steel studs spaced at 24" o.c.</li> <li>• optional mineral wool or glass fiber insulation</li> <li>• 2 layers 5/8" gypsum board on each side</li> </ul>		2 h	55 (GFB 2 1/2")
UL U412	<ul style="list-style-type: none"> <li>• 1 5/8" x 1 1/4" x 25 MSG steel studs spaced at 24" o.c.</li> <li>• optional glass fibre or mineral wool insulation</li> <li>• 2 layers 1/2" gypsum board on each side</li> </ul>		2 h	-
UL U415	<b>System A</b> <ul style="list-style-type: none"> <li>• 2 1/2" x 25 MSG "C-H" shaped studs spaced at 24" o.c.</li> <li>• 1 layer 1" gypsum liner board panels on one side</li> <li>• 1 layer of 5/8" gypsum wallboard on other side</li> </ul>		1 h	-
	<b>System B</b> <ul style="list-style-type: none"> <li>• 2 1/2" x 25 MSG "C-H" shaped studs spaced at 24" o.c.</li> <li>• 1 layer 1" gypsum liner board panels on one side</li> <li>• 2 layers of 1/2" or 5/8" gypsum wallboard on other side</li> </ul>		2 h	-

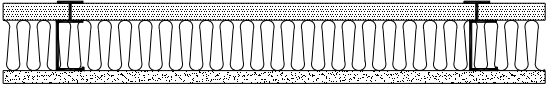
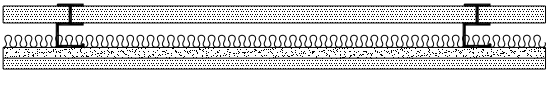
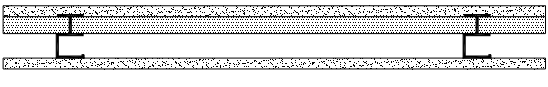
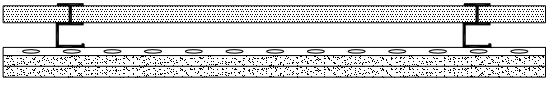
**Non-Load Bearing Walls – Underwriters Laboratories Inc.**

Source	Description	Fire Resistance Rating	Sound Transmission Class
UL U415 (cont.)	<p>System C</p> <ul style="list-style-type: none"> <li>• 4" x 25 MSG "C-H" shaped studs spaced at 24" o.c.</li> <li>• 3" min. mineral wool batts</li> <li>• 1 layer 1" gypsum liner board panels on one side</li> <li>• 1 layer of 3/4" gypsum wallboard on other side</li> </ul>		
	2 h	-	
	<p>System D</p> <ul style="list-style-type: none"> <li>• 2 1/2" x 20 MSG "C-H" shaped studs spaced at 24" o.c.</li> <li>• 1 layer 1" gypsum liner board panels on one side</li> <li>• 1 1/2" min. mineral wool batts</li> <li>• 1 layer of 5/8" gypsum wallboard and 1 layer of 1/2" or 5/8" cementitious board designated "Durock" on other side</li> </ul>		
	2 h	-	
<p>System E</p> <ul style="list-style-type: none"> <li>• 2 1/2" x 25 MSG "C-H" shaped studs spaced at 24" o.c.</li> <li>• 1 layer 1" gypsum liner board panels on one side</li> <li>• 1 layer of 1/2" or 5/8" gypsum wallboard on each side</li> </ul>			
2 h	-		
<p>System F</p> <ul style="list-style-type: none"> <li>• 2 1/2" x 25 MSG "C-H" shaped studs spaced at 24" o.c.</li> <li>• 1 layer 1" gypsum liner board panels on one side</li> <li>• furring channels spaced at 24" o.c.</li> <li>• 2 layers of 1/2" or 5/8" gypsum wallboard on other side</li> </ul>			
2 h	-		

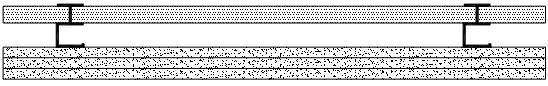
**Non-Load Bearing Walls – Underwriters Laboratories Inc.**

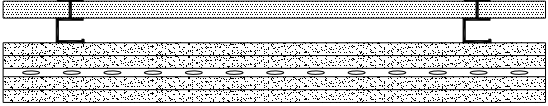
Source	Description	Fire Resistance Rating	Sound Transmission Class
UL U415 (cont.)	<p><b>System G</b></p> <ul style="list-style-type: none"> <li>• 2 ½" x 25 MSG "C-H" shaped studs spaced at 24" o.c.</li> <li>• 1 layer 1" gypsum liner board panels on one side</li> <li>• 3 layers of 5/8" gypsum wallboard on other side</li> </ul>		<p>3 h</p> <p>-</p>
	<p><b>System H</b></p> <ul style="list-style-type: none"> <li>• 2 ½" x 25 MSG "C-H" shaped studs spaced at 24" o.c.</li> <li>• 1 layer 1" gypsum liner board panels on one side</li> <li>• 2 layers of 5/8" gypsum wallboard on other side</li> </ul>		<p>3 h</p> <p>-</p>
	<p><b>System I</b></p> <ul style="list-style-type: none"> <li>• 2 ½" x 25 MSG "C-H" shaped studs spaced at 24" o.c.</li> <li>• 1 layer 1" gypsum liner board panels on one side</li> <li>• 4 layers of 3/4" gypsum wallboard on other side</li> <li>• furring channels spaced at 24" o.c. and applied over second layer</li> </ul>		<p>4 h</p> <p>-</p>

**Non-Load Bearing Walls – Underwriters Laboratories Inc.**

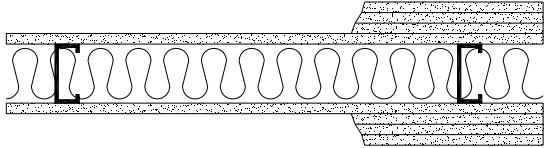
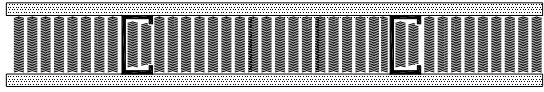
Source	Description	Fire Resistance Rating	Sound Transmission Class																																							
<p><b>UL U419</b></p> <p>a) SA870717                      b) SA860620                      c) RAL-TL90-166                      d) USG860808                      e) USG910617                      f) SA830112                      g) SA830113                      h) USG910907</p>	<ul style="list-style-type: none"> <li>min 25 MSG steel studs with 1 1/4" flanges, spaced at 24" o.c.</li> <li>mineral wool insulation optional except where required as noted by asterisk and described below</li> <li>stud depth, gypsum board layers, gypsum board thickness, and corresponding rating as shown</li> </ul> <p>* 1 1/2" mineral wool insulation                      ** 3" mineral wool insulation                      *** 2" mineral wool insulation</p>																																									
			<table border="1"> <thead> <tr> <th data-bbox="878 554 974 604">1 h</th> <th data-bbox="974 554 1068 604">#Layer &amp; Size</th> <th data-bbox="1068 554 1177 604">Stud Depth</th> <th data-bbox="1177 554 1472 1119" rowspan="13">                     49<sup>a</sup> (RFB 3")                      51<sup>b&amp;c</sup> (RFB 3 1/2")                      40<sup>d</sup> (NI)                       50<sup>e</sup>                      59<sup>f</sup> (RFB 1 1/2")                       62<sup>g</sup> (RFB 1 1/2")                      56<sup>h</sup> </th> </tr> </thead> <tbody> <tr> <td data-bbox="878 604 974 646">1 h</td> <td data-bbox="974 604 1068 646">1-5/8</td> <td data-bbox="1068 604 1177 646">3-1/2</td> </tr> <tr> <td data-bbox="878 646 974 688">1 h</td> <td data-bbox="974 646 1068 688">1-1/2</td> <td data-bbox="1068 646 1177 688">2-1/2*</td> </tr> <tr> <td data-bbox="878 688 974 730">1 h</td> <td data-bbox="974 688 1068 730">1-3/4</td> <td data-bbox="1068 688 1177 730">1-5/8</td> </tr> <tr> <td data-bbox="878 730 974 772">2 h</td> <td data-bbox="974 730 1068 772">2-1/2</td> <td data-bbox="1068 730 1177 772">1-5/8</td> </tr> <tr> <td data-bbox="878 772 974 814">2 h</td> <td data-bbox="974 772 1068 814">2-5/8</td> <td data-bbox="1068 772 1177 814">1-5/8</td> </tr> <tr> <td data-bbox="878 814 974 856">2 h</td> <td data-bbox="974 814 1068 856">1-3/4</td> <td data-bbox="1068 814 1177 856">3-1/2**</td> </tr> <tr> <td data-bbox="878 856 974 898">3 h</td> <td data-bbox="974 856 1068 898">3-1/2</td> <td data-bbox="1068 856 1177 898">1-5/8</td> </tr> <tr> <td data-bbox="878 898 974 940">3 h</td> <td data-bbox="974 898 1068 940">2-3/4</td> <td data-bbox="1068 898 1177 940">1-5/8</td> </tr> <tr> <td data-bbox="878 940 974 982">3 h</td> <td data-bbox="974 940 1068 982">3-5/8</td> <td data-bbox="1068 940 1177 982">1-5/8</td> </tr> <tr> <td data-bbox="878 982 974 1024">4 h</td> <td data-bbox="974 982 1068 1024">4-5/8</td> <td data-bbox="1068 982 1177 1024">1-5/8</td> </tr> <tr> <td data-bbox="878 1024 974 1066">4 h</td> <td data-bbox="974 1024 1068 1066">4-1/2</td> <td data-bbox="1068 1024 1177 1066">1-5/8</td> </tr> <tr> <td data-bbox="878 1066 974 1119">4 h</td> <td data-bbox="974 1066 1068 1119">2-3/4</td> <td data-bbox="1068 1066 1177 1119">2-1/2***</td> </tr> </tbody> </table>	1 h	#Layer & Size	Stud Depth	49 <sup>a</sup> (RFB 3") 51 <sup>b&amp;c</sup> (RFB 3 1/2") 40 <sup>d</sup> (NI)  50 <sup>e</sup> 59 <sup>f</sup> (RFB 1 1/2")  62 <sup>g</sup> (RFB 1 1/2") 56 <sup>h</sup>	1 h	1-5/8	3-1/2	1 h	1-1/2	2-1/2*	1 h	1-3/4	1-5/8	2 h	2-1/2	1-5/8	2 h	2-5/8	1-5/8	2 h	1-3/4	3-1/2**	3 h	3-1/2	1-5/8	3 h	2-3/4	1-5/8	3 h	3-5/8	1-5/8	4 h	4-5/8	1-5/8	4 h	4-1/2	1-5/8	4 h	2-3/4
		1 h	#Layer & Size	Stud Depth	49 <sup>a</sup> (RFB 3") 51 <sup>b&amp;c</sup> (RFB 3 1/2") 40 <sup>d</sup> (NI)  50 <sup>e</sup> 59 <sup>f</sup> (RFB 1 1/2")  62 <sup>g</sup> (RFB 1 1/2") 56 <sup>h</sup>																																					
		1 h	1-5/8	3-1/2																																						
		1 h	1-1/2	2-1/2*																																						
		1 h	1-3/4	1-5/8																																						
		2 h	2-1/2	1-5/8																																						
		2 h	2-5/8	1-5/8																																						
		2 h	1-3/4	3-1/2**																																						
		3 h	3-1/2	1-5/8																																						
		3 h	2-3/4	1-5/8																																						
		3 h	3-5/8	1-5/8																																						
		4 h	4-5/8	1-5/8																																						
4 h	4-1/2	1-5/8																																								
4 h	2-3/4	2-1/2***																																								
<p><b>UL U431</b></p>	<ul style="list-style-type: none"> <li>3 5/8" x 1 1/4" x 25 MSG steel studs spaced at 16" o.c.</li> <li>metal lath, diamond mesh, expanded steel 3.4 lbs per sq. yd.</li> <li>3/4" thick plaster on each side</li> <li>spray-applied fire resistive material sprayed in stud cavity</li> </ul>																																									
		4 h	-																																							

**Non-Load Bearing Walls – Underwriters Laboratories Inc.**

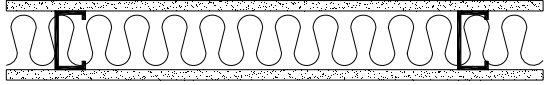
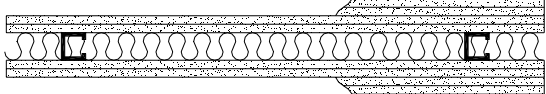
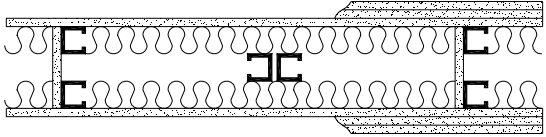
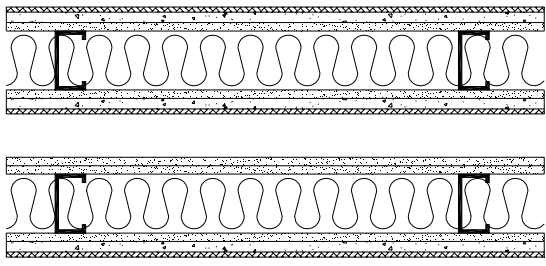
Source	Description	Fire Resistance Rating	Sound Transmission Class																
UL U432	<ul style="list-style-type: none"> <li>3 1/2" x 20 MSG steel studs spaced at 24" o.c.</li> <li>optional glass fiber or mineral wool insulation</li> <li>5/8" gypsum board on each side</li> </ul>																		
		1 h	-																
UL U435 a) SA830112 b) SA830113	<ul style="list-style-type: none"> <li>1 5/8" x 1 1/4" x 25 MSG steel studs spaced at 16" or 24" o.c.</li> <li>optional mineral wool insulation</li> <li>4 layers 1/2" gypsum board on each side for 4 h</li> <li>3 layers 1/2" or 2 layers 3/4" gypsum board on each side for 3 h</li> </ul>																		
		3 h 4 h	59 <sup>a</sup> (RFB 1 1/2") 62 <sup>b</sup> (RFB 1 1/2")																
UL U436	<ul style="list-style-type: none"> <li>1 5/8" x 1" x 25 MSG steel studs spaced at 24" o.c.</li> <li>steel truss members in cavity between steel studs</li> <li>optional glass fiber or mineral wool insulation</li> <li>gypsum wallboard layers, wallboard thickness and corresponding rating as shown</li> </ul>																		
		<table border="1"> <thead> <tr> <th></th> <th>#Layer &amp; Size</th> <th></th> </tr> </thead> <tbody> <tr> <td>1 h</td> <td>1-5/8</td> <td rowspan="6">-</td> </tr> <tr> <td>2 h</td> <td>2-1/2</td> </tr> <tr> <td>2 h</td> <td>2-5/8</td> </tr> <tr> <td>3 h</td> <td>2-3/4</td> </tr> <tr> <td>3 h</td> <td>3-1/2</td> </tr> <tr> <td>3 h</td> <td>3-5/8</td> </tr> </tbody> </table>		#Layer & Size		1 h	1-5/8	-	2 h	2-1/2	2 h	2-5/8	3 h	2-3/4	3 h	3-1/2	3 h	3-5/8	
	#Layer & Size																		
1 h	1-5/8	-																	
2 h	2-1/2																		
2 h	2-5/8																		
3 h	2-3/4																		
3 h	3-1/2																		
3 h	3-5/8																		
UL U443 SA851028	<ul style="list-style-type: none"> <li>3 5/8" x 1 1/4" x 20 MSG steel studs spaced at 24" o.c.</li> <li>3" min "Thermafiber" insulation</li> <li>inner layer 1/2" gypsum board on each side</li> <li>1 layer 1/2" or 5/8" cementitious board on each side</li> <li>outer layer 1/4" ceramic tile on each side</li> </ul>	 <p style="text-align: center;">Alternate Construction</p>																	
		2 h *see UL listing for Alternate design	58 (CEMBRD 1/2")																

## Non-Load Bearing Walls – Underwriters Laboratories Inc.

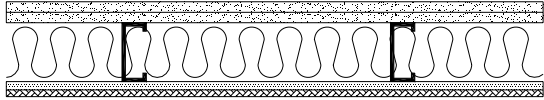
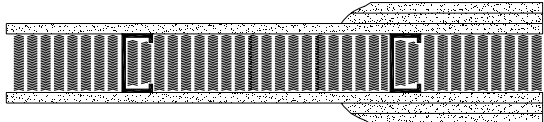
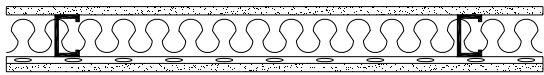
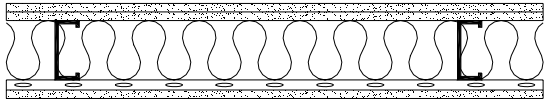
Source	Description	Fire Resistance Rating	Sound Transmission Class										
UL U449	<ul style="list-style-type: none"> <li>• 3 5/8" x 1 3/8" x 20 MSG steel studs spaced at 16" o.c.</li> <li>• 3 5/8" insulation having min 3.5 pcf</li> <li>• 2 layers 5/8" gypsum board on one side</li> <li>• inner layer of 7/16" mineral and fiber board, and outer layer of ceramic tile on other side</li> </ul>												
		1-1/2 h	<50*										
UL U450	<ul style="list-style-type: none"> <li>• 2 1/2" x 1 1/4" x 25 MSG (1 h), 3 5/8" x 1 1/4" x 25 MSG (3 h) and 3 5/8" x 1 1/4" x 18 MSG (4 h) steel studs spaced at 16" o.c.</li> <li>• spray-applied fire resistive material sprayed in stud cavity</li> <li>• gypsum wallboard layers, wallboard thickness and corresponding rating as shown</li> </ul>												
		<table border="1"> <tr> <td></td> <td style="text-align: center;">#Layer &amp; Size</td> <td style="text-align: center;">-</td> </tr> <tr> <td style="text-align: center;">1 h</td> <td style="text-align: center;">1-5/8</td> <td></td> </tr> <tr> <td style="text-align: center;">3 h</td> <td style="text-align: center;">2-5/8</td> <td></td> </tr> <tr> <td style="text-align: center;">4 h</td> <td style="text-align: center;">3-5/8</td> <td></td> </tr> </table>		#Layer & Size	-	1 h	1-5/8		3 h	2-5/8		4 h	3-5/8
	#Layer & Size	-											
1 h	1-5/8												
3 h	2-5/8												
4 h	3-5/8												
UL U451	<ul style="list-style-type: none"> <li>• 2 1/2" x 1 1/4" x 25 MSG steel studs spaced at 24" o.c.</li> <li>• 1 1/2" min "Thermafiber" insulation</li> <li>• steel resilient channel, 25 MSG on one side spaced at 24" o.c.</li> <li>• 1 layer of 1/2" or 5/8" gypsum board on each side</li> </ul>												
		1 h	-										
UL U452  RAL-TL83-215	<ul style="list-style-type: none"> <li>• 3 1/2" x 1 1/4" x 20 MSG steel studs spaced at 24" o.c.</li> <li>• 3" min "Thermafiber" insulation</li> <li>• 2 layers 1/2" gypsum board on one side</li> <li>• steel resilient channels, 25 ga, spaced at 24" o.c.</li> <li>• 1 layer 1/2" gypsum board on other side</li> </ul>												
		1-1/2 h	-										

\* Estimated value as per Warnock (2008)

**Non-Load Bearing Walls – Underwriters Laboratories Inc.**

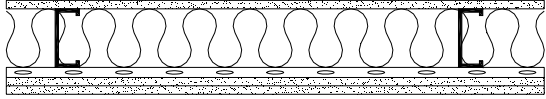
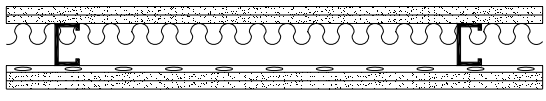
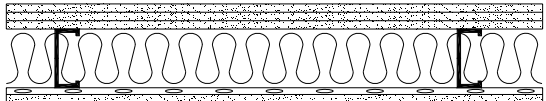
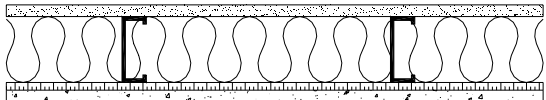
Source	Description	Fire Resistance Rating	Sound Transmission Class
UL U453	<ul style="list-style-type: none"> <li>• 3 ½" x 1 ¼" x 20 MSG steel studs spaced at 24" o.c.</li> <li>• 3" min "Thermafiber" insulation</li> <li>• 1 layer of ½" gypsum board on one side</li> <li>• steel resilient channels, 25 ga, spaced at 24" o.c.</li> <li>• 2 layers of ½" gypsum board on other side</li> </ul>		<p style="text-align: center;">2 h</p> <p style="text-align: center;">-</p>
UL U454	<ul style="list-style-type: none"> <li>• 2 ½" x 1 ¼" x 25 MSG steel studs spaced at 24" o.c.</li> <li>• 1 " min "Thermafiber" mineral wool insulation</li> <li>• steel resilient channel, 25 MSG on one side spaced at 24" o.c.</li> <li>• 2 layers of ½" gypsum board on each side</li> </ul>		<p style="text-align: center;">2 h</p> <p style="text-align: center;">-</p>
UL U455	<ul style="list-style-type: none"> <li>• 3 ½" x 1 ¼" x 20 MSG steel studs spaced at 24" o.c.</li> <li>• 3" min "Thermafiber" insulation</li> <li>• 3 layers of ½" gypsum board on one side</li> <li>• steel resilient channels, 25 MSG spaced at 24" o.c.</li> <li>• 2 layers of ½" gypsum board on other side</li> </ul>		<p style="text-align: center;">3 h</p> <p style="text-align: center;">-</p>
UL U457  USG840222	<ul style="list-style-type: none"> <li>• 3 ⅝" x 1 ¼" x 20 MSG steel studs spaced at 16" o.c.</li> <li>• 1 layer ⅝" gypsum board on one side</li> <li>• 3" min "Thermafiber" insulation</li> <li>• inner layer of ½" rigid polystyrene insulation (optional), and outer layer of ½" or ⅝" cementitious board on other side</li> </ul>		<p style="text-align: center;">1 h</p> <p style="text-align: center;">50 (CEMBRD ½")</p>

## Non-Load Bearing Walls – Underwriters Laboratories Inc.

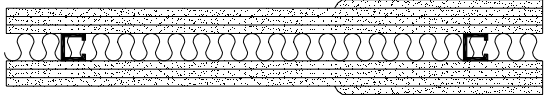
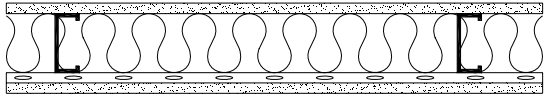
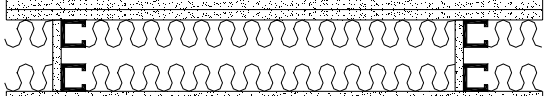
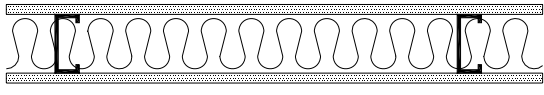
Source	Description	Fire Resistance Rating	Sound Transmission Class
UL U463	<ul style="list-style-type: none"> <li>1 5/8" x 1 1/4" x 25 MSG steel studs spaced at 16" or 24" o.c.</li> <li>optional 1 1/2" thick batts and blankets or spray applied cellulose insulation</li> <li>4 layers 1/2" gypsum board on each side for 4 h</li> <li>3 layers 1/2" gypsum board on each side for 3 h</li> </ul>		
		3 h 4 h	-
UL U465  a) SA870717 b) SA860620 c) RAL-TL90-166	<ul style="list-style-type: none"> <li>3 5/8" x 1 1/4" x 25 MSG steel studs spaced at 24" o.c.</li> <li>optional mineral wool or glass fiber insulation</li> <li>optional steel resilient channels, 25ga, spaced at 24" o.c.</li> <li>1 layer 5/8" gypsum board on each side</li> </ul>		
		1 h	49 <sup>a</sup> (RFB 3") 51 <sup>b &amp; c</sup> (RFB 3 1/2") 51* (RFB 3 1/2" RC)
UL U466	<ul style="list-style-type: none"> <li>1 5/8" x 1 1/4" x 25 MSG steel studs spaced at 24" o.c.</li> <li>optional glass fiber or mineral wool batts and blankets or spray applied cellulose insulation</li> <li>2 layers 5/8" gypsum board on one side</li> <li>1 layer 5/8" gypsum board on other side</li> </ul>		
		1 h	-
UL U471	<ul style="list-style-type: none"> <li>3 5/8" x 1 1/4" x 25 MSG steel studs spaced at 24" o.c.</li> <li>3 1/4" min mineral wool batt insulation having min 4 pcf or spray applied cellulose insulation</li> <li>1 layer 0.591" mineral and fiber board, designated "Promat-H" on each side</li> </ul>		
		1-1/2 h	-

\* Estimated value as per Warnock (2008)

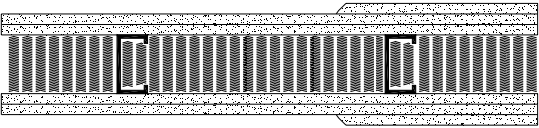
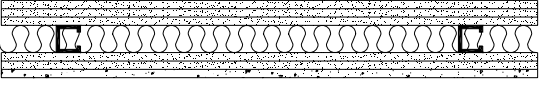
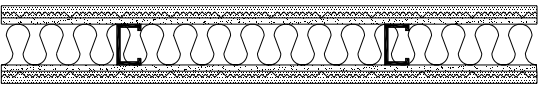

**Non-Load Bearing Walls – Underwriters Laboratories Inc.**

Source	Description	Fire Resistance Rating	Sound Transmission Class																		
UL U475	<ul style="list-style-type: none"> <li>• min 25 MSG (1, 2 and 3 h), and 18 MSG (4 h) steel studs with x 1 1/4" legs, spaced at 16" o.c.</li> <li>• metal lath, diamond mesh, expanded steel 3.4 lbs per sq. yd.</li> <li>• stud depth, min thickness of material applied to metal lath, and corresponding rating as shown</li> <li>• cementitious mixture, spray-applied fire resistive material sprayed or vermiculate concrete in stud cavity</li> <li>• 2 layers 5/8" gypsum board on each side for 1, 2 and 3 h and 3 layers 5/8" gypsum board on each side for 4 h</li> </ul>																				
		<table border="1" style="width: 100%; border-collapse: collapse;"> <thead> <tr> <th style="width: 15%;"></th> <th style="width: 25%;">Cavity Material</th> <th style="width: 25%;">Stud Depth</th> <th style="width: 35%;"></th> </tr> </thead> <tbody> <tr> <td>1 h</td> <td>2</td> <td>2-1/2</td> <td style="text-align: center;">-</td> </tr> <tr> <td>2 h</td> <td>2-3/4</td> <td>3-1/4</td> <td></td> </tr> <tr> <td>3 h</td> <td>3-1/4</td> <td>3-5/8</td> <td></td> </tr> <tr> <td>4 h</td> <td>4</td> <td>4</td> <td></td> </tr> </tbody> </table>		Cavity Material	Stud Depth		1 h	2	2-1/2	-	2 h	2-3/4	3-1/4		3 h	3-1/4	3-5/8		4 h	4	4
	Cavity Material	Stud Depth																			
1 h	2	2-1/2	-																		
2 h	2-3/4	3-1/4																			
3 h	3-1/4	3-5/8																			
4 h	4	4																			
UL U478	<ul style="list-style-type: none"> <li>• 1 5/8" x 1 1/4" x 25 MSG steel studs spaced at 24" o.c.</li> <li>• optional mineral wool or spray applied cellulose insulation filling stud cavity</li> <li>• 3 layers 1/2" gypsum board on one side</li> <li>• inner 2 layers 1/2" thick gypsum board and outer layer 1/2" or 5/8" cementitious board on other side</li> </ul>		3 h																		
UL U484	<ul style="list-style-type: none"> <li>• 2 1/2" x 1 1/4" x 20 MSG steel stud spaced at 16" o.c.</li> <li>• optional "Thermafiber" insulation</li> <li>• 1 layer 3/8" gypsum board on each side</li> <li>• metal lath and 3/4" plaster on each side</li> </ul>		2 h																		
		<50*																			

\* Estimated value as per Warnock (2008)

**Non-Load Bearing Walls – Underwriters Laboratories Inc.**

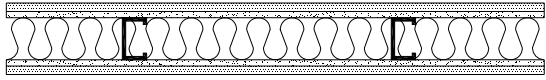
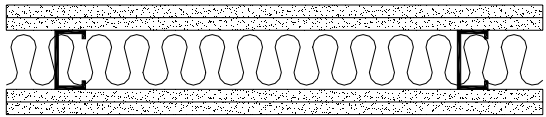
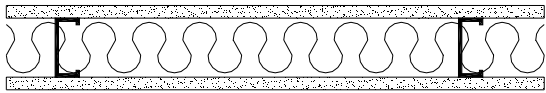
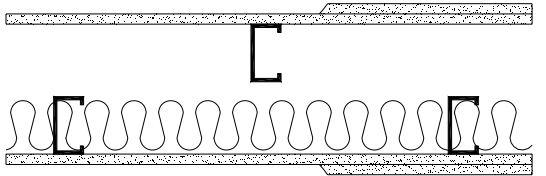
Source	Description	Fire Resistance Rating	Sound Transmission Class
UL U488	<ul style="list-style-type: none"> <li>• 2 ½" x 1¼" x 20 MSG steel stud spaced at 16" o.c.</li> <li>• 1" min. "Thermafiber" insulation</li> <li>• 1 layer ⅜" gypsum board on each side</li> <li>• 7/16" plaster on each side</li> </ul>		
		1 h	<50*
UL U490  USG910907	<ul style="list-style-type: none"> <li>• 2 ½" x 1¼" x 25 MSG steel stud spaced at 24" o.c.</li> <li>• 2" nominal "Thermafiber" insulation</li> <li>• 2 layers ¾" gypsum board on each side</li> </ul>		
		4 h	56
UL U491  USG910617	<ul style="list-style-type: none"> <li>• 3 ½" x 1¼" x 25 MSG steel stud spaced at 24" o.c.</li> <li>• 3" nominal "Thermafiber" insulation</li> <li>• 1 layer ¾" gypsum board on each side</li> </ul>		
		2 h	50
UL U493	<ul style="list-style-type: none"> <li>• 2 ½" x 1 ⅝" x 25 MSG steel studs spaced at 24" o.c.</li> <li>• 3 ½" glass fiber insulation on one side of wall assembly with nom. density of 0.5 pcf</li> <li>• 1 hour - 1 layer ⅝" or ¾" gypsum board on each side</li> <li>• 2 hour – 2 layers ⅝" gypsum board on each side</li> </ul>		
		1 h 2 h	-

\* Estimated value as per Warnock (2008)

## Non-Load Bearing Walls – Underwriters Laboratories Inc.

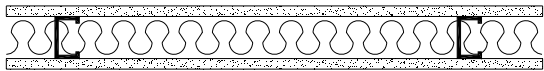
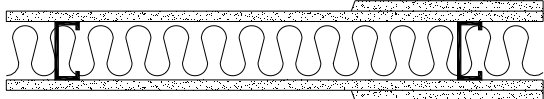
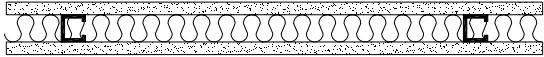
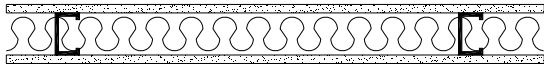
Source	Description	Fire Resistance Rating	Sound Transmission Class
UL U494	<ul style="list-style-type: none"> <li>• 2 ½" x 1¼" x 25 MSG steel stud spaced at 16" or 24" o.c.</li> <li>• 2 ½" glass fiber batts</li> <li>• 1 layer ⅝" gypsum board on each side</li> </ul>		
		1 h	-
UL U495  a) SA860620 b) RAL-TL90-166	<ul style="list-style-type: none"> <li>• 3 ⅝" x 1¼" x 25 MSG steel studs spaced at 24" o.c.</li> <li>• optional mineral wool or glass fiber insulation</li> <li>• 1 hour - 1 layer ⅝" or ¾" gypsum board on each side</li> <li>• 2 hour – 2 layers ⅝" gypsum board on each side</li> </ul>		
		1 h	51 <sup>a&amp;b</sup> (G ⅝" RFB 3½")
		2 h	53* (G ¾" RFB 3½") 58* (RFB 3½")
UL U496	<ul style="list-style-type: none"> <li>• 1 ⅝" x 1¼" x 25 MSG steel studs spaced at 24" o.c.</li> <li>• optional mineral wool batts filling stud cavity</li> <li>• ¾" gypsum board on each side</li> </ul>		
		1 h	-
UL V401	<ul style="list-style-type: none"> <li>• 2 ½" x 1⅜" x 25 ga steel stud spaced at 24" o.c.</li> <li>• 2" mineral wool insulation with UL Classification Marking</li> <li>• 1 layer ½" gypsum board on each side</li> </ul>		
		1 h	47*

\* Estimated value as per Warnock (2008)

## Non-Load Bearing Walls – Underwriters Laboratories Inc.

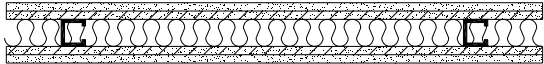
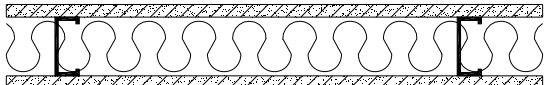
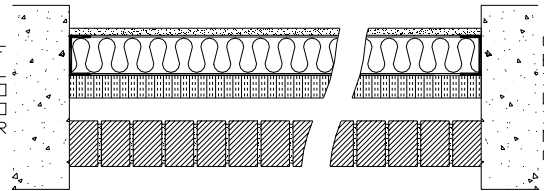
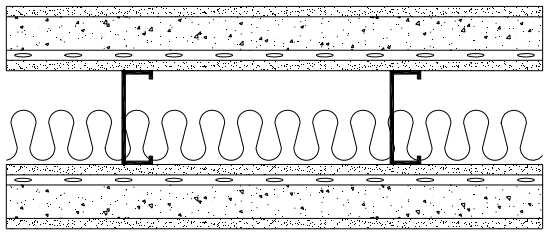
Source	Description	Fire Resistance Rating	Sound Transmission Class
UL V410	<ul style="list-style-type: none"> <li>• 1 5/8" x 1 1/4" x 25 MSG steel studs spaced at 24" o.c.</li> <li>• optional mineral wool or glass fiber batts filling stud cavity</li> <li>• 1/2" "building unit" gypsum board on each side</li> <li>• 1/2" gypsum board on each side</li> </ul>		
		2 h	-
UL V412	<ul style="list-style-type: none"> <li>• 3 1/2" x 1 1/4" x 25 MSG steel stud spaced at 24" o.c.</li> <li>• 3" nominal mineral wool batts</li> <li>• 3/4" "building unit" gypsum board on each side</li> </ul>		
		2 h	-
UL V414	<ul style="list-style-type: none"> <li>• 3 5/8" x 1 5/8" x 20 MSG steel studs spaced at 16" o.c.</li> <li>• 3 1/2" glass fiber insulation</li> <li>• 1 layer 5/8" gypsum board on one side</li> <li>• 1 layer 2" foamed plastic board on other side</li> <li>• 4" brick veneer</li> </ul>		
		3 h Interior 1 h Exterior	-
UL V415	<ul style="list-style-type: none"> <li>• 5 5/8" x 1 5/8" x 20 MSG steel stud spaced at 16" o.c.</li> <li>• 3 1/2" mineral wool or spray applied cellulose insulation</li> <li>• inner layer 5/8" gypsum board on each side</li> <li>• hat shaped furring channels spaced 24" o.c. on each side</li> <li>• 2" structural cement fiber units designated "Fibrochahl" or "Fibroplank" on each side</li> <li>• outer layer 5/8" gypsum board on each side</li> </ul>		
		2 h	-

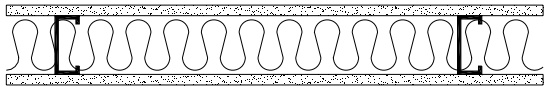
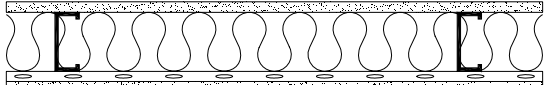
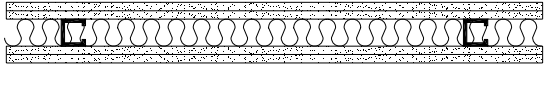
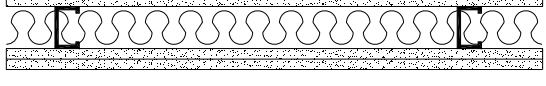

\* Estimated value as per Warnock (2008)

**Non-Load Bearing Walls – Underwriters Laboratories Inc.**

Source	Description	Fire Resistance Rating	Sound Transmission Class
UL V416  USG860808	<ul style="list-style-type: none"> <li>• 3 5/8" x 1 1/4" x 25 MSG steel studs spaced at 24" o.c.</li> <li>• optional mineral wool or glass fiber insulation</li> <li>• 1 layer 5/8" or 3/4" gypsum board on each side</li> </ul>		
		1 h	40 (G 5/8" NI) 43* (G 3/4" NI) 53* (G 3/4" RFB 3/2")
UL V417	<ul style="list-style-type: none"> <li>• 3 5/8" x 1 1/4" x 25 MSG steel studs spaced at 24" o.c.</li> <li>• mineral wool batts filling stud cavity</li> <li>• optional steel resilient channels, 25 MSG, spaced at 24" o.c.</li> <li>• 1 layer 5/8" gypsum board on each side</li> </ul>		
		1 h	-
UL V418	<ul style="list-style-type: none"> <li>• 1 5/8" x 1 1/4" x 25 MSG steel studs spaced at 24" o.c.</li> <li>• mineral wool batts filling stud cavity</li> <li>• 2 layers 1/2" gypsum board on each side</li> </ul>		
		2 h	-
UL V419	<ul style="list-style-type: none"> <li>• 2 1/2" x 1 1/4" x 25 MSG steel stud spaced at 24" o.c.</li> <li>• mineral wool batts filling stud cavity</li> <li>• 2 layers 5/8" gypsum board on each side</li> </ul>		
		2 h	-

\* Estimated value as per Warnock (2008)

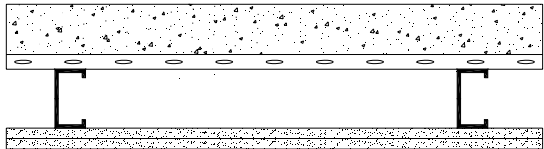
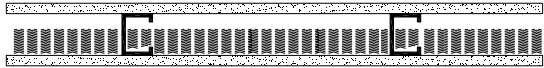
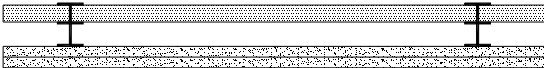
**Non-Load Bearing Walls – Underwriters Laboratories Inc.**

Source	Description	Fire Resistance Rating	Sound Transmission Class
UL V420	<ul style="list-style-type: none"> <li>• 3 1/2" x 20 MSG steel stud spaced at 24" o.c.</li> <li>• min 3" thick and max 2' wide precast autoclaved aerated concrete panels on one side</li> <li>• 7/8" furring channels spaced 24" o.c. on one side</li> <li>• 2 layers of 5/8" gypsum board on other side</li> </ul>		
UL V425	<ul style="list-style-type: none"> <li>• 2 1/2" x 1 1/4" x 25 MSG steel studs spaced at 16" o.c.</li> <li>• 1 1/2" spray-applied fire resistive material sprayed in stud cavity</li> <li>• 1 layer 5/8" gypsum board on each side</li> </ul>		
UL V433	<p>System A</p> <ul style="list-style-type: none"> <li>• 2 1/2" x 1 1/2" x 25 MSG "I"-shaped steel studs spaced 24" o.c. with 3/4" wide by 2 1/4" high holding tabs</li> <li>• 1" gypsum board on one side</li> <li>• 2 layers of 1/2" or 5/8" gypsum board on other side</li> </ul>		
	<p>System B</p> <ul style="list-style-type: none"> <li>• 2 1/2" x 1 1/2" x 25 MSG "I"-shaped steel studs spaced 24" o.c. with 3/4" wide by 2 1/4" high holding tabs</li> <li>• inner layer of 1" gypsum board on one side</li> <li>• 1 layer of 1/2" or 5/8" gypsum board on each side</li> </ul>		

**Non-Load Bearing Walls – Underwriters Laboratories Inc.**

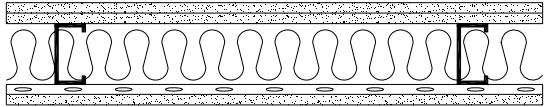
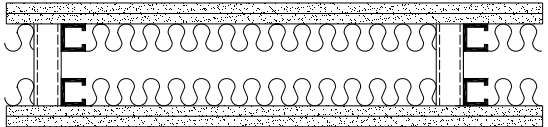
Source	Description	Fire Resistance Rating	Sound Transmission Class
UL V433 (cont.)	<p><b>System C</b></p> <ul style="list-style-type: none"> <li>• 2 1/2" x 1 1/2" x 25 MSG "I"-shaped steel studs spaced 24" o.c. with 3/4" wide by 2 1/4" high holding tabs</li> <li>• 1" gypsum board on one side</li> <li>• 1 layer of 5/8" gypsum board on other side</li> </ul>	 <p>1 h</p>	-
UL V435	<ul style="list-style-type: none"> <li>• 3 5/8" x 1 1/4" x 25 MSG steel studs spaced at 24" o.c.</li> <li>• mineral wool batts filling stud cavity with min. 2.5 pcf density</li> <li>• steel resilient channels, 25 MSG, spaced at 24" o.c. on one side</li> <li>• 1 layer 5/8" gypsum board on one side</li> <li>• 2 layers of 5/8" gypsum board on other side</li> </ul>	 <p>1 h</p>	52
UL V437	<ul style="list-style-type: none"> <li>• 1 5/8" x 1 1/4" x 25 MSG steel studs spaced at 24" o.c.</li> <li>• mineral wool or glass fiber batts</li> <li>• 2 layers 5/8" gypsum board on each side</li> <li>• steel runners or stud bracing, cavity width, spaced 48" o.c.</li> </ul>	 <p>1 h</p>	-

**Non-Load Bearing Walls – Underwriters Laboratories Inc.**

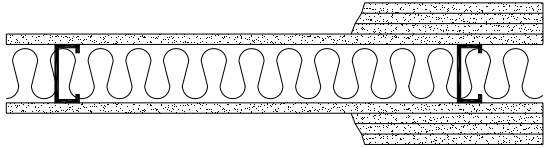
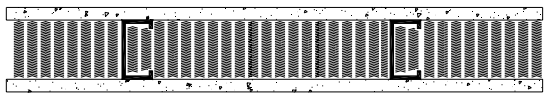
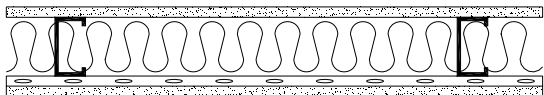
Source	Description	Fire Resistance Rating	Sound Transmission Class																																			
UL V438	<ul style="list-style-type: none"> <li>• min 25 MSG steel studs with 1¼” flanges, spaced at 24” o.c.</li> <li>• mineral wool insulation optional except where required as noted by asterisk and described below</li> <li>• stud depth, gypsum board layers, gypsum board thickness, and corresponding rating as shown</li> </ul> <p>* 2” mineral wool insulation</p>		-																																			
				<table border="1" style="width: 100%; border-collapse: collapse;"> <thead> <tr> <th style="width: 15%;"></th> <th style="width: 20%;">#Layer &amp; Size</th> <th style="width: 20%;">Stud Depth</th> <th style="width: 45%;"></th> </tr> </thead> <tbody> <tr> <td>1 h</td> <td>1-5/8</td> <td>3 5/8</td> <td></td> </tr> <tr> <td>1 h</td> <td>1-1/2</td> <td>2 1/2*</td> <td></td> </tr> <tr> <td>2 h</td> <td>2-1/2</td> <td>1 5/8</td> <td></td> </tr> <tr> <td>2 h</td> <td>2-5/8</td> <td>2 1/2</td> <td></td> </tr> <tr> <td>3 h</td> <td>3-1/2</td> <td>1 5/8</td> <td></td> </tr> <tr> <td>3 h</td> <td>3-5/8</td> <td>1 5/8</td> <td></td> </tr> <tr> <td>4 h</td> <td>4-1/2</td> <td>1 5/8</td> <td></td> </tr> <tr> <td>4 h</td> <td>4-5/8</td> <td>1 5/8</td> <td></td> </tr> </tbody> </table>		#Layer & Size	Stud Depth		1 h	1-5/8	3 5/8		1 h	1-1/2	2 1/2*		2 h	2-1/2	1 5/8		2 h	2-5/8	2 1/2		3 h	3-1/2	1 5/8		3 h	3-5/8	1 5/8		4 h	4-1/2	1 5/8		4 h	4-5/8
			#Layer & Size	Stud Depth																																		
		1 h	1-5/8	3 5/8																																		
		1 h	1-1/2	2 1/2*																																		
		2 h	2-1/2	1 5/8																																		
		2 h	2-5/8	2 1/2																																		
		3 h	3-1/2	1 5/8																																		
		3 h	3-5/8	1 5/8																																		
4 h	4-1/2	1 5/8																																				
4 h	4-5/8	1 5/8																																				
UL V443	<ul style="list-style-type: none"> <li>• 3 5/8” x 1 1/4” x 25 MSG steel studs spaced at 16” o.c.</li> <li>• metal lath, diamond mesh, expanded steel 3.4 lbs per sq. yd.</li> <li>• vermiculate concrete pumped into stud cavity</li> <li>• 3/4” plaster (sand &amp; unfibered gypsum) on one side</li> <li>• 3/4” portland cement plaster (cement, lime &amp; sand) on other side</li> </ul>		-																																			
				4 h	-																																	
UL V444	<ul style="list-style-type: none"> <li>• 3 5/8” x 1 1/4” x 25 MSG steel studs spaced at 24” o.c.</li> <li>• optional mineral wool or glass fiber batts</li> <li>• optional steel resilient channels, 25 MSG, spaced at 24” o.c.</li> <li>• 1 layer 5/8” gypsum board on each side</li> <li>• non-metallic plumbing system components in stud cavity attached to horizontal cross bracing (steel or lumber)</li> </ul>		-																																			
				1 h	-																																	

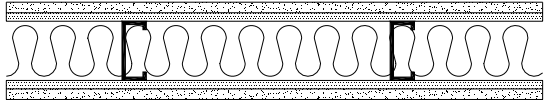
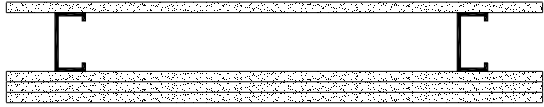
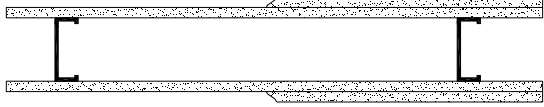

**Non-Load Bearing Walls – Underwriters Laboratories Inc.**

Source	Description	Fire Resistance Rating	Sound Transmission Class
UL V448	<ul style="list-style-type: none"> <li>• 3 5/8" x 1 1/4" x 25 MSG steel studs spaced at 16" o.c.</li> <li>• nom. 3" mineral wool batts, min. 3.4 pcf, friction fit</li> <li>• inner layer 1/2" mineral and fiber board designated "Homasote Type 440-32" on each side</li> <li>• outer layer 5/8" gypsum board on each side</li> </ul>		<p>1 h</p> <p>-</p>
UL V449	<ul style="list-style-type: none"> <li>• 3 1/2" x 1 1/4" x 25 MSG steel studs spaced at 24" o.c.</li> <li>• 1 layer 5/8" gypsum board on one side</li> <li>• 3 layers 5/8" gypsum board on other side</li> </ul>		<p>2 h</p> <p>-</p>
<p>UL V450</p> <p>RAL-TL05-078</p>	<ul style="list-style-type: none"> <li>• 3 5/8" (1 hour), 2 1/2" (2 or 2 1/2 hour) and 1 5/8" (2 hour) <b>proprietary</b> steel stud (Dietrich Industries Inc. or Clark Western Building Systems Inc.) with 0.0150" thickness spaced at 24" o.c.</li> <li>• 1 hour - 1 layer of 5/8" gypsum board on each side</li> <li>• 2 and 2 1/2 hour – 2 layers of 5/8" gypsum board on each side</li> <li>• optional glass fiber or mineral wool insulation friction fit in stud cavities</li> <li>• optional steel resilient channel, 25 MSG on one side spaced at 24" o.c.</li> </ul>		<p>1 h</p> <p>2 h</p> <p>2 1/2 h</p> <p>39 (NI)</p> <p>48 (GFB 3 5/8")</p> <p>52 (GFB 3 5/8" RC)</p> <p>61 (GFB 3 5/8" RC)</p> <p>-</p>

**Non-Load Bearing Walls – Underwriters Laboratories Inc.**

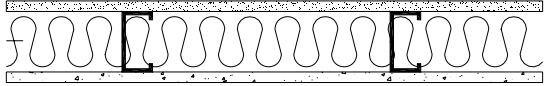
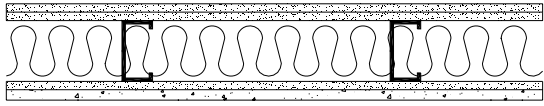
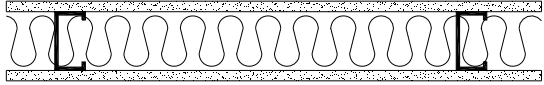
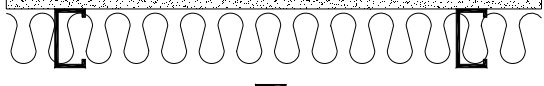
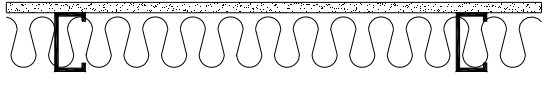
Source	Description	Fire Resistance Rating	Sound Transmission Class
UL V452	<ul style="list-style-type: none"> <li>• 3 5/8" x 1 1/4" x 25 MSG steel studs spaced at 16" o.c.</li> <li>• nom. 3" mineral wool batts, min. 2.6 pcf, friction fit</li> <li>• 1 layer 1/2", 5/8", 3/4 or 1" cementitious backer units on one side</li> <li>• 1 layer 5/8" thick gypsum board on other side</li> </ul>	 <p style="text-align: center;">1 h</p>	-
	<ul style="list-style-type: none"> <li>• 3 5/8" x 1 1/4" x 25 MSG steel studs spaced at 16" o.c.</li> <li>• nom. 3" mineral wool batts, min. 2.6 pcf, friction fit</li> <li>• 2 layers 1/2" gypsum board on one side</li> <li>• inner layer of 1/2" thick gypsum, outer layer of 1/2", 5/8", 3/4 or 1" cementitious backer units on other side</li> </ul>	 <p style="text-align: center;">2 h</p>	-
UL V463	<ul style="list-style-type: none"> <li>• 3 1/2" x 1 1/2" x 25 MSG steel stud spaced as follows: Configuration A: 16" or 24" o.c.</li> <li>• 3 1/2" glass fiber insulation with nom. density of 0.95 pcf</li> <li>• 1 layer of 5/8" "QuietRock" soundproof drywall on each side</li> </ul>	 <p style="text-align: center;">Wall Configuration A</p>  <p style="text-align: center;">Wall Configuration B</p>  <p style="text-align: center;">Wall Configuration C</p> <p style="text-align: center;">1 h</p>	-

**Non-Load Bearing Walls – Underwriters Laboratories Inc.**

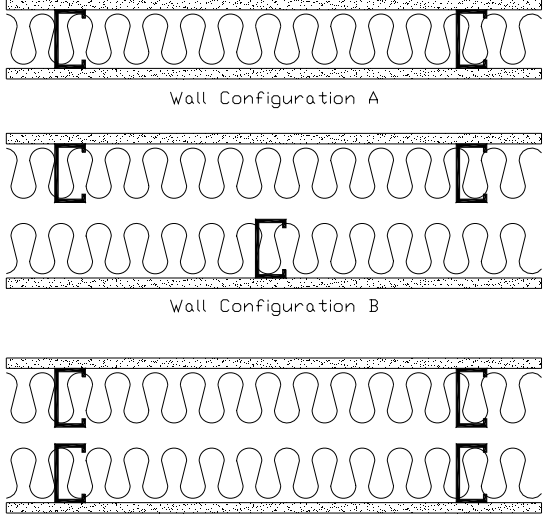
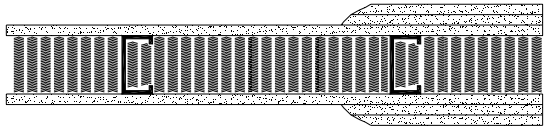
Source	Description	Fire Resistance Rating	Sound Transmission Class								
<p>UL V464 RAL TL07-069</p>	<ul style="list-style-type: none"> <li>3 5/8" <b>proprietary</b> steel stud (Dietrich Industries Inc. or Clark Western Building Systems Inc.) with 0.0150" thickness and spaced as follows: Configuration A: 16" or 24" o.c. Configuration B: 8" or 12" o.c. Configuration C: 16" or 24" o.c.</li> <li>3 1/2" glass fiber insulation with nom. density of 0.95 pcf</li> <li>1 layer of 5/8" "QuietRock" soundproof drywall on one side and 1 layer of 5/8" Type X gypsum board on other side</li> </ul>	 <p>Wall Configuration A</p> <p>Wall Configuration B</p> <p>Wall Configuration C</p>									
		<p>1 h</p>	<p>55 (Configuration A) 56* (Configuration B) 61* (Configuration C)</p>								
<p>UL V476</p>	<ul style="list-style-type: none"> <li>min 25 MSG (1, and 3 h), and min 18 MSG (4 h) steel studs with 1 1/4" legs, spaced at 16" o.c.</li> <li>metal lath, diamond mesh, expanded steel 3.4 lbs per sq. yd.</li> <li>stud depth, gypsum board layers, gypsum board thickness and corresponding rating as shown</li> <li>spray-applied fire resistive material sprayed in stud cavity</li> </ul>										
<p>1 h 3 h 4 h</p>	<table border="1"> <thead> <tr> <th># Layer &amp; Size</th> <th>Stud Depth</th> </tr> </thead> <tbody> <tr> <td>1 - 5/8"</td> <td>3 5/8" or 2 1/2"</td> </tr> <tr> <td>2 - 5/8"</td> <td>3 5/8"</td> </tr> <tr> <td>3 - 5/8"</td> <td>3 5/8"</td> </tr> </tbody> </table>	# Layer & Size	Stud Depth	1 - 5/8"	3 5/8" or 2 1/2"	2 - 5/8"	3 5/8"	3 - 5/8"	3 5/8"		<p>-</p>
# Layer & Size	Stud Depth										
1 - 5/8"	3 5/8" or 2 1/2"										
2 - 5/8"	3 5/8"										
3 - 5/8"	3 5/8"										

\* Estimated value (see [www.quietsolution.com/acousticfireassemblies.pdf](http://www.quietsolution.com/acousticfireassemblies.pdf))

**Non-Load Bearing Walls – Underwriters Laboratories Inc.**

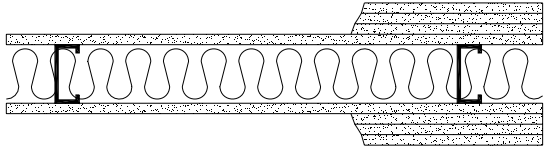
Source	Description	Fire Resistance Rating	Sound Transmission Class																																				
UL V477	<ul style="list-style-type: none"> <li>• min 25 MSG steel studs with 1¼” flanges, spaced at 24” o.c.</li> <li>• mineral wool batts friction fitted between studs, optional except where required as noted by asterisk and described below</li> <li>• stud depth, drywall layers, drywall thickness, and corresponding rating as shown</li> </ul> <p>* 1½” mineral wool batts                      ** 3” mineral wool batts                      *** 2” mineral wool batts</p>		-																																				
				<table border="1"> <thead> <tr> <th></th> <th>Stud Depth</th> <th># Layer &amp; Size</th> </tr> </thead> <tbody> <tr><td>1 h</td><td>3½</td><td>1 - 5/8</td></tr> <tr><td>1 h</td><td>2½</td><td>1 - 1/2 *</td></tr> <tr><td>1 h</td><td>1 5/8</td><td>1 - 3/4</td></tr> <tr><td>2 h</td><td>1 5/8</td><td>2 - 1/2</td></tr> <tr><td>2 h</td><td>1 5/8</td><td>2 - 5/8</td></tr> <tr><td>2 h</td><td>3½</td><td>1 - 3/4 **</td></tr> <tr><td>3 h</td><td>1 5/8</td><td>3 - 1/2</td></tr> <tr><td>3 h</td><td>1 5/8</td><td>2 - 3/4</td></tr> <tr><td>3 h</td><td>1 5/8</td><td>3 - 5/8</td></tr> <tr><td>4 h</td><td>1 5/8</td><td>4 - 5/8</td></tr> <tr><td>4 h</td><td>1 5/8</td><td>4 - 1/2</td></tr> <tr><td>4 h</td><td>2½</td><td>2 - 3/4 ***</td></tr> </tbody> </table>		Stud Depth	# Layer & Size	1 h	3½	1 - 5/8	1 h	2½	1 - 1/2 *	1 h	1 5/8	1 - 3/4	2 h	1 5/8	2 - 1/2	2 h	1 5/8	2 - 5/8	2 h	3½	1 - 3/4 **	3 h	1 5/8	3 - 1/2	3 h	1 5/8	2 - 3/4	3 h	1 5/8	3 - 5/8	4 h	1 5/8	4 - 5/8	4 h	1 5/8
	Stud Depth	# Layer & Size																																					
1 h	3½	1 - 5/8																																					
1 h	2½	1 - 1/2 *																																					
1 h	1 5/8	1 - 3/4																																					
2 h	1 5/8	2 - 1/2																																					
2 h	1 5/8	2 - 5/8																																					
2 h	3½	1 - 3/4 **																																					
3 h	1 5/8	3 - 1/2																																					
3 h	1 5/8	2 - 3/4																																					
3 h	1 5/8	3 - 5/8																																					
4 h	1 5/8	4 - 5/8																																					
4 h	1 5/8	4 - 1/2																																					
4 h	2½	2 - 3/4 ***																																					

## Non-Load Bearing Walls – Gypsum Association

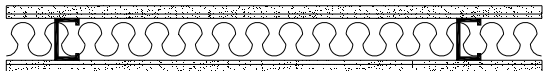
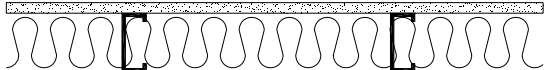
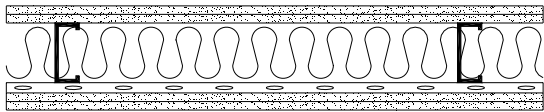
Source	Description	Fire Resistance Rating	Sound Transmission Class
GA WP1041  ASL AS-TL1510	<ul style="list-style-type: none"> <li>• 3 5/8" x 20 gage steel studs spaced at 24" o.c.</li> <li>• inner layer 1/2" Type X gypsum board and outer layer 1/4" fiber-cement board on each side</li> </ul>		
		1 h	50 to 54
GA WP1051  NGC 2318	<ul style="list-style-type: none"> <li>• 2 1/2" steel studs spaced at 24" o.c.</li> <li>• 2" glass fiber insulation</li> <li>• inner layer 1/4" gypsum board and outer layer 1/2" Type X gypsum board on each side</li> </ul>		
		1 h	53
GA WP1082  NGC 2099015	<ul style="list-style-type: none"> <li>• 3 5/8" x 25 gage steel studs spaced at 16" o.c.</li> <li>• 3" mineral fiber insulation</li> <li>• 1 layer 5/8" Type X gypsum board on one side</li> <li>• 1 layer 1/2" cementitious board on other side</li> </ul>		
		1 h	45 to 49
GA WP1470  RAL TL83-214	<ul style="list-style-type: none"> <li>• 3 1/2" x 20 gage steel studs spaced at 24" o.c.</li> <li>• 3" mineral fiber insulation</li> <li>• 2 layers 1/2" Type X gypsum board on one side</li> <li>• resilient channels spaced 24" o.c. and 2 layers 1/2" Type X gypsum board on other side</li> </ul>		
		2 h	55 to 59

## Non-Load Bearing Walls – Gypsum Association

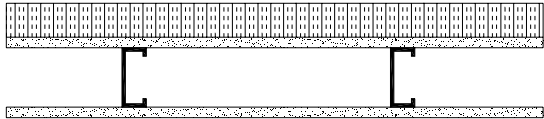
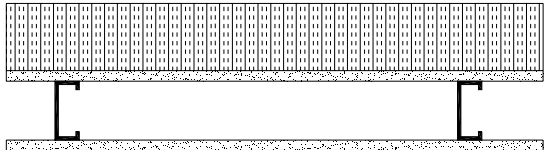
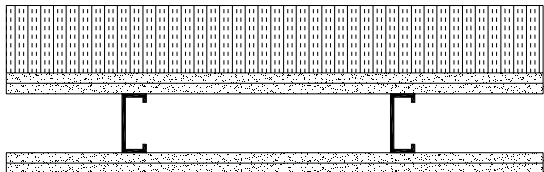
Source	Description	Fire Resistance Rating	Sound Transmission Class
GA WP8003	<ul style="list-style-type: none"> <li>• 3 5/8" x 20 gage steel studs spaced at 24" o.c.</li> <li>• 1 layer 5/8" Type X gypsum board on one side</li> <li>• inner layer of 1/2" Type X gypsum board and outer layer of 1/4" fiber-cement board on other side</li> </ul>		
		1 h	-
GA WP8122	<ul style="list-style-type: none"> <li>• 3 5/8" x 18 gage steel studs spaced at 16" o.c.</li> <li>• 1 layer 5/8" Type X gypsum board on one side</li> <li>• inner layer of 5/8" Type X gypsum board and outer layer of 2" expanded polystyrene on other side</li> </ul>		
		1 h	-
GA WP8123	<ul style="list-style-type: none"> <li>• 3 5/8" x 18 gage steel studs spaced at 24" o.c.</li> <li>• 1 layer 5/8" Type X gypsum board on one side</li> <li>• inner layer of 5/8" Type X gypsum board and outer layer of 4" expanded polystyrene on other side</li> </ul>		
		2 h	-
GA WP8202	<ul style="list-style-type: none"> <li>• 3 5/8" x 18 gage steel studs spaced at 16" o.c.</li> <li>• 2 layers 5/8" Type X gypsum board on one side</li> <li>• 2 layers of 5/8" Type X gypsum board and 4" expanded polystyrene on other side</li> </ul>		
		2 h	-

## Non-Load Bearing Walls – Gypsum Association

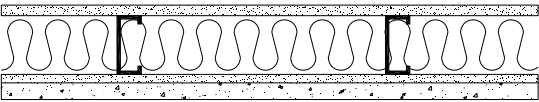
Source	Description	Fire Resistance Rating	Sound Transmission Class
GA WP8250	<ul style="list-style-type: none"> <li>• 3 5/8" x 20 gage steel studs spaced at 16" o.c.</li> <li>• 3" mineral fiber insulation</li> <li>• 1 layer 5/8" foil backed Type X gypsum board on one side</li> <li>• 1/2" gypsum board with stucco finish on other side</li> </ul>		-
		2 h	-

## Non-Load Bearing Walls – Factory Mutual Research

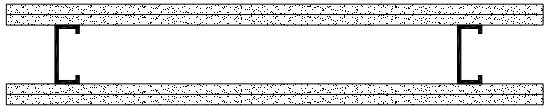
Source	Description	Fire Resistance Rating	Sound Transmission Class
FM Wall 1 USG810519	<ul style="list-style-type: none"> <li>• 3 5/8" x 22 ga steel studs spaced at 24" o.c.</li> <li>• 1 layer 5/8" gypsum board on each side</li> </ul>		1 h      40
FM Wall 7 BBN760808	<ul style="list-style-type: none"> <li>• 3 5/8" x 22 ga steel studs spaced at 24" o.c.</li> <li>• 2 layers 5/8" gypsum board on each side</li> </ul>		2 h      48

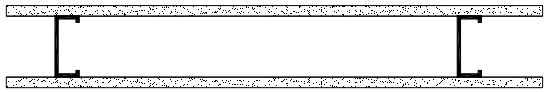
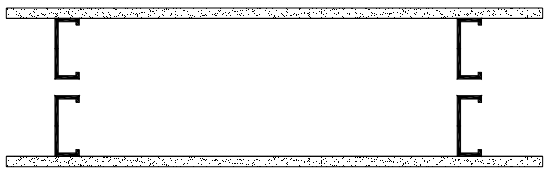
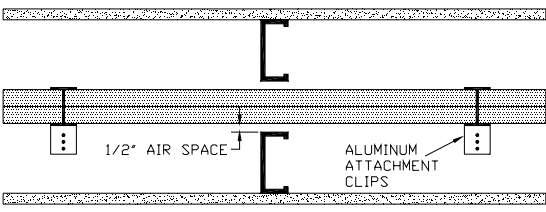

## Non-Load Bearing Walls – Intertek Group plc

Source	Description	Fire Resistance Rating	Sound Transmission Class
Intertek MWWA 60-02 60-04  TL08-119 Western Electro – Acoustic Laboratory	<ul style="list-style-type: none"> <li>3 5/8", 4" or 6" depth <b>proprietary</b> steel stud (Marino\WARE or CEMCO) designated as VIPERSTUD25™ with 0.0155" thickness* spaced at 24" o.c.</li> <li>1 layer 5/8" Type X gypsum board on each side</li> </ul>		
		1 h	41
Intertek MWWA 60-03 60-05	<ul style="list-style-type: none"> <li>two rows of 3 5/8", 4" or 6" depth <b>proprietary</b> steel stud (Marino\WARE or CEMCO) designated as VIPERSTUD25™ with 0.0155" thickness* spaced at 24" o.c.</li> <li>min 1" spacing between studs from each row</li> <li>1 layer 5/8" Type X gypsum board on each side</li> </ul>		
		1 h	-
Intertek MWWA 120-03	<p>Firewall (max. height – 50 feet)</p> <ul style="list-style-type: none"> <li>2" deep x 25 gauge <b>proprietary</b> "H" shaped steel studs (Marino\WARE or CEMCO) spaced at 24" o.c.</li> <li>2 layers of 1" thick Type X gypsum wallboard liner panels</li> </ul> <p>Protected Wall (Bearing or Nonbearing Wall)</p> <ul style="list-style-type: none"> <li>min. 3 1/2" depth steel stud spaced at 24" o.c.</li> <li>1 layer 1/2" Type C gypsum board</li> <li>aluminum attachment clips</li> </ul>	 <p style="text-align: center;">EXPOSED TO FIRE FROM SEPARATION WALL SIDE ONLY</p>	
		2 h	-

\* Larger thickness is also acceptable.

## Non-Load Bearing Walls – Intertek Group plc

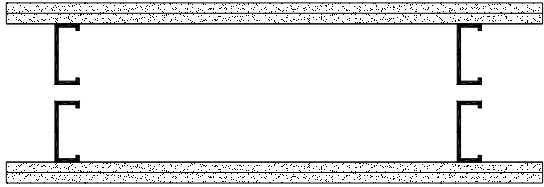
Source	Description	Fire Resistance Rating	Sound Transmission Class
Intertek MWWA 120-04 120-05  TL08-124 Western Electro – Acoustic Laboratory	<ul style="list-style-type: none"> <li>1 5/8", 2 1/2", 3 5/8", 4" or 6" depth <b>proprietary</b> steel stud (Marino\WARE or CEMCO) designated as VIPERSTUD25™ with 0.0155" thickness* spaced at 24" o.c.</li> <li>2 layers 5/8" Type X gypsum board on each side</li> </ul> NOTE: Optional 3 1/2" fibreglass insulation required with resilient channel for STC=61 and using 3 5/8" steel stud.		
		2 h	61
Intertek MWWA 120-06 120-07	<ul style="list-style-type: none"> <li>1 5/8", 2 1/2", 3 5/8", 4" or 6" depth <b>proprietary</b> steel stud (Marino\WARE or CEMCO) designated as VIPERSTUD25™ with 0.0155" thickness* spaced at 24" o.c.</li> <li>min 1" spacing between studs from each row</li> <li>2 layers 5/8" Type X gypsum board on each side</li> </ul>		
		2 h	-

\* Larger thickness is also acceptable.

# **LOAD BEARING WALL ASSEMBLIES**

## Load Bearing Walls – Underwriters’ Laboratories of Canada

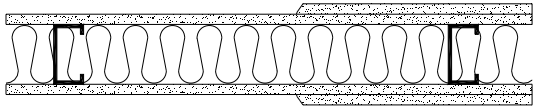
Source	Description	Fire Resistance Rating	Sound Transmission Class
ULC W416	<ul style="list-style-type: none"> <li>• 92 mm x 42 mm x 0.9 mm thick <b>proprietary</b> steel stud (Rotary Press Systems Inc.) spaced at 600 mm o.c.</li> <li>• 89 mm glass fibre batts friction fitted between studs</li> <li>• 1 hour - 1 layer 15.9 mm gypsum board on each side</li> <li>• 2 hour – 2 layers 15.9 mm gypsum board on each side</li> </ul>		

## Load Bearing Walls – Underwriters’ Laboratories of Canada

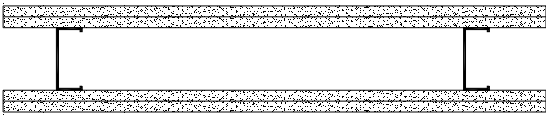
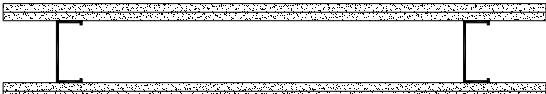
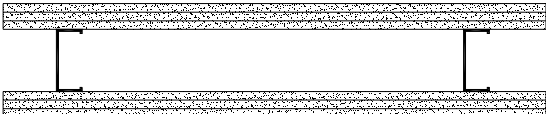
Source	Description	Fire Resistance Rating	Sound Transmission Class
<p><b>ULC W424</b></p> <p>a) USG810519 b) BBN760808</p>	<ul style="list-style-type: none"> <li>92 mm x 35 mm <b>proprietary</b> steel stud (Bailey Metal Products Ltd.), 0.9 mm thick spaced at 600 mm o.c.</li> <li>1 layer of 15.9 mm Type X gypsum board (Canadian Gypsum Company, Sheetrock Firecode C) on each side</li> </ul>	 <p>1 h</p>	<p>40<sup>a</sup></p>
	<ul style="list-style-type: none"> <li>92 mm x 35 mm <b>proprietary</b> steel stud (Bailey Metal Products Ltd.), 0.9 mm thick spaced at 600 mm o.c.</li> <li>2 layers of 15.9 mm Type X gypsum board (Canadian Gypsum Company, Sheetrock Firecode C) on each side</li> </ul> <p>** 60% of Design Load</p>	 <p>** 2 h</p>	<p>48<sup>b</sup></p>
	<ul style="list-style-type: none"> <li>92 mm x 35 mm <b>proprietary</b> steel stud (Bailey Metal Products Ltd.), 0.9 mm thick spaced at 600 mm o.c.</li> <li>2 layers of 12.7 mm Type X gypsum board (Canadian Gypsum Company, Sheetrock Firecode C) on each side</li> </ul> <p>** 85% of Design Load</p>	 <p>** 1-1/2 h</p>	<p>&lt;50*</p>
	<ul style="list-style-type: none"> <li>92 mm x 35 mm <b>proprietary</b> steel stud (Bailey Metal Products Ltd.), 0.9 mm thick spaced at 600 mm o.c.</li> <li>3 layers of 12.7 mm Type X gypsum board (Canadian Gypsum Company, Sheetrock Firecode C) on each side</li> </ul> <p>** 60% of Design Load</p>	 <p>** 2 h</p>	<p>50*</p>

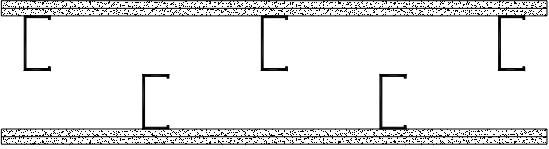
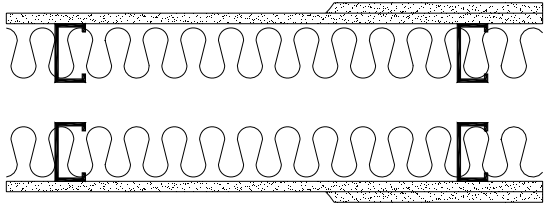

\* Estimated value as per Warnock (2008)

## Load Bearing Walls – Underwriters’ Laboratories of Canada

Source	Description	Fire Resistance Rating	Sound Transmission Class
ULC W445	<ul style="list-style-type: none"> <li>double wall system with min 7 mm space between each 92 mm x 41 mm x 0.80 mm thick steel stud spaced at 400 mm o.c.</li> <li>2 layers of 12.7 mm gypsum board on each side</li> </ul>		
		1-½ h	54*
ULC W449	<ul style="list-style-type: none"> <li>double wall system with 89 mm x 41 mm x 0.86 mm thick steel stud spaced at 610 mm o.c.</li> <li>any glass fibre insulation with ULC Listing Mark with min. density of 8.0 kg/m<sup>3</sup></li> <li>1 or 2 layers of 15.9 mm gypsum board on each side</li> </ul> <p>** 80% of Design Load</p>		
		**1 h for 1–15.9mm 2 h for 2-15.9mm	58* (AIR 25mm) 59* (AIR 50mm) 68* (AIR 25mm) 69* (AIR 50mm)

\* Estimated value as per Warnock (2008)

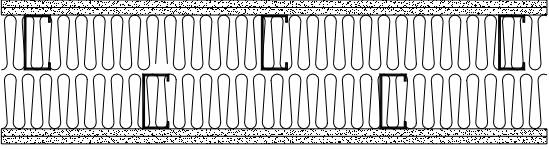
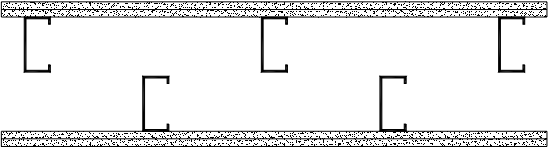
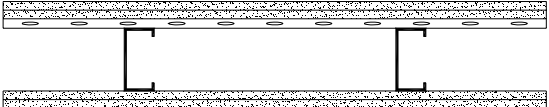
## Load Bearing Walls – National Research Council of Canada

Source	Description	Fire Endurance	Sound Transmission Class
NRCC A4222.2 F26	<ul style="list-style-type: none"> <li>double wall system with 92 mm deep x 0.91 mm thick steel stud spaced at 406 mm o.c.</li> <li>39 mm wide diagonal strap bracing with 101 x 101 x 0.912 mm gusset plates</li> <li>90 mm mineral fibre insulation</li> <li>2 layers of 12.7 mm Type X gypsum board on each side</li> </ul>		
		84 min	64*
NRCC A4222.2 F30 F30R  TLA-01-019a	<ul style="list-style-type: none"> <li>double wall system with 92 mm deep x 0.91 mm thick steel stud spaced at 406 mm o.c.</li> <li>39 mm wide diagonal strap bracing with 101 x 101 x 0.912 mm gusset plates</li> <li>2 layers of 12.7 mm Type X gypsum board on each side</li> </ul> <p>NOTE: F30R used to measure the repeatability of the results.</p>		
		F30 -100 min F30R -102 min	55
NRCC A4222.2 F37	<ul style="list-style-type: none"> <li>92 mm deep steel stud with 0.91 mm thickness spaced at 406 mm o.c.</li> <li>39 mm wide diagonal strap bracing with 101 x 101 x 0.912 mm gusset plates</li> <li>steel resilient channels spaced 406 mm o.c.</li> <li>2 layers of 12.7 mm Type X gypsum board on each side</li> </ul>		
		77 min	46*
NRCC A4222.2 F39	<ul style="list-style-type: none"> <li>92 mm deep steel stud with 0.91 mm thickness spaced at 406 mm o.c.</li> <li>39 mm wide diagonal strap bracing with 101 x 101 x 0.912 mm gusset plates</li> <li>2 layers of 12.7 mm Type X gypsum board on each side</li> </ul>		
		83 min	<50*

\* Estimated value as per Warnock (2008)

## Load Bearing Walls – National Research Council of Canada

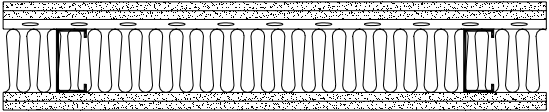
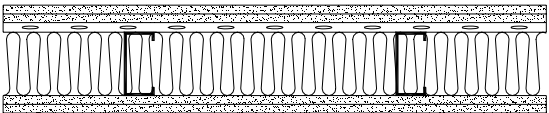
Source	Description	Fire Endurance	Sound Transmission Class
NRCC A4222.2 F28	<ul style="list-style-type: none"> <li>92 mm deep steel stud with 0.91 mm thickness spaced at 610 mm o.c.</li> <li>39 mm wide diagonal strap bracing with 101 x 101 x 0.912 mm gusset plates</li> <li>steel resilient channels spaced 406 mm o.c.</li> <li>90 mm mineral fibre insulation</li> <li>2 layers of 12.7 mm Type X gypsum board on each side</li> </ul>		
		74 min	56*
NRCC A4222.2 F35 F36	<ul style="list-style-type: none"> <li>92 mm deep steel stud with 0.84 mm thickness spaced at 406 mm o.c.</li> <li>39 mm wide diagonal strap bracing with 101 x 101 x 0.912 mm gusset plates</li> <li>steel resilient channels spaced 406 mm o.c.</li> <li>90 mm glass fibre insulation</li> <li>2 layers of 12.7 mm Type X gypsum board on each side</li> </ul> <p>NOTE: Applied load varies between two tests; F35=78.4kN, F36=70.9kN</p>		
		F35 = 68 min F36 = 63 min	55*

\* Estimated value as per Warnock (2008)

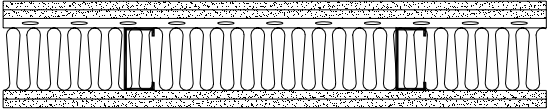

## Load Bearing Walls – National Research Council of Canada

Source	Description	Fire Endurance	Sound Transmission Class
NRCC A4222.2 F27 F31 F38	<ul style="list-style-type: none"> <li>• 92 mm deep steel stud with 0.91 mm thickness spaced at 406 mm o.c.</li> <li>• 39 mm wide diagonal strap bracing with 101 x 101 x 0.912 mm gusset plates</li> <li>• steel resilient channels spaced 406 mm o.c.</li> <li>• insulation (see below)</li> <li>• 2 layers of 12.7 mm Type X gypsum board on each side</li> </ul> <p>F27 - 90 mm glass fibre insulation F31 - 90 mm cellulose insulation F38 - 90 mm mineral fibre insulation</p>		
		<p>F27 = 56 min F31 = 71 min F38 = 59 min</p>	<p>55* 54* 54*</p>

\* Estimated value as per Warnock (2008)

### References:

Kodur, V.K.R., Sultan, M.A., Latour, J.C., Leroux, P. and Monette, R.C., *Fire Resistance Tests on Gypsum Board-Protected Loadbearing Steel Stud Walls*, IRC Client Report No. A-4222.2, National Research Council of Canada, Ottawa, Ontario, Canada, February 2002.

\* Warnock, A.C.C., *Estimation of Sound Transmission Class and Impact Insulation Class Rating for Steel Framed Assemblies*, Report No. B3436.1, Institute for Research in Construction, National Research Council of Canada, Ottawa, Ontario, Canada, December 2005.

## Load Bearing Walls – Underwriters Laboratories Inc.

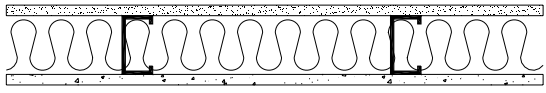
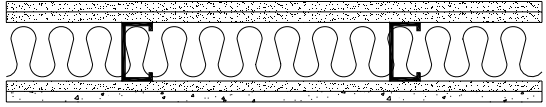
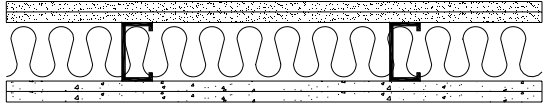
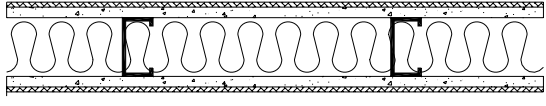
Source	Description	Fire Resistance Rating	Sound Transmission Class	
UL U404	<ul style="list-style-type: none"> <li>• 3 1/2" x 20 MSG steel studs spaced at 16" o.c.</li> <li>• 3" mineral wool insulation</li> <li>• 1 layer 1/2" or 5/8" cementitious board on one side</li> <li>• 1 layer 5/8" thick gypsum board on other side</li> </ul>		1 h	<50*
	<ul style="list-style-type: none"> <li>• 3 1/2" x 20 MSG steel studs spaced at 16" o.c.</li> <li>• 3" mineral wool insulation</li> <li>• 2 layers 5/8" gypsum board on one side</li> <li>• inner layer of 5/8" thick gypsum, outer layer of 1/2" or 5/8" cementitious board on other side</li> </ul>	 Configuration A	2 h	<50*
	<ul style="list-style-type: none"> <li>• 3 1/2" x 20 MSG steel studs spaced at 16" o.c.</li> <li>• 3" mineral wool insulation</li> <li>• 2 layers 1/2" or 5/8" cementitious board on one side</li> <li>• 2 layers 5/8" thick gypsum board on other side</li> </ul>	 Configuration B	2 h	<50*
UL U407  USG840321	<ul style="list-style-type: none"> <li>• 3 1/2" x 20 MSG steel studs spaced at 16" o.c.</li> <li>• 3" mineral wool insulation</li> <li>• 5/8" cementitious board, ceramic tiles and exterior finish on either side</li> </ul>		1 h	48

\* Estimated value as per Warnock (2008)

## Load Bearing Walls – Underwriters Laboratories Inc.

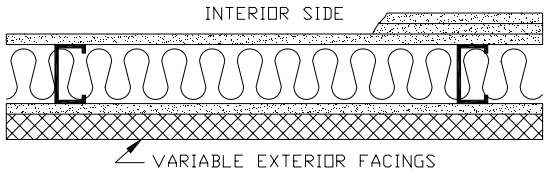
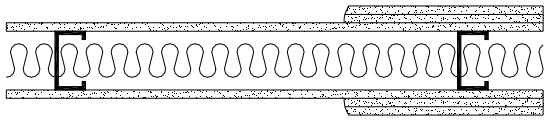
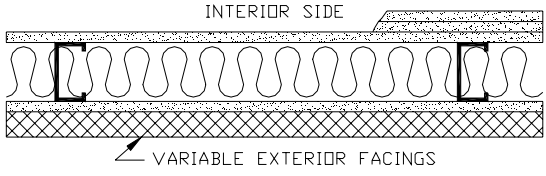
Source	Description	Fire Resistance Rating	Sound Transmission Class
UL U418	<ul style="list-style-type: none"> <li>• 3 ½" or 5 ½" x 1 ½" x 18 GSG (0.051" thick) steel stud spaced at 24" o.c.</li> <li>• 3 ½" glass fiber batts</li> <li>• gypsum board on interior side (rating listed for thickness of gypsum and number of layers applied)</li> <li>• 1 layer of ½" gypsum sheathing on exterior side</li> </ul> <p>NOTE: Exposed to fire on interior face only.</p>		
		45 min for 1 layer 5/8 in. 1 h for 2 layers 1/2 in. 2 h for 3 layers 1/2 in.	- - -
UL U423  a) USG810518 b) USG810519 c) USG811006	<ul style="list-style-type: none"> <li>• 3 ½" x 20 MSG steel stud spaced at 24" o.c.</li> <li>• optional glass fiber or mineral wool insulation</li> <li>• optional steel resilient channels spaced 24" o.c.</li> <li>• gypsum board on each side (rating listed for thickness of gypsum and number of layers applied)</li> <li>* 80% of Design Load.</li> <li>** 2" mineral wool insulation</li> </ul>		
		45 min for 1 layer 1/2 in. 1 h for 1 layer 5/8 in. 1-1/2 h for 2 layers 1/2 in. * 2 h for 2 layers 5/8 in. ** 2 h for 2 layers 3/8 in. 2 h for 3 layers 1/2 in. 2 h for 2 layers 3/4 in.	- 41 <sup>a</sup> (RFB 2") 40 <sup>b</sup> (NI) - - 48 <sup>c</sup> (RFB 2") - -
UL U424	<ul style="list-style-type: none"> <li>• 3 ½" x 1 ½" x 20 MSG steel stud spaced at 24" o.c.</li> <li>• optional glass fiber or mineral wool insulation</li> <li>• optional steel resilient channels spaced 24" o.c.</li> <li>• gypsum board on interior side (rating listed for thickness of gypsum and number of layers applied)</li> <li>• 1 layer of ½" or 5/8" gypsum board on exterior side</li> </ul> <p>NOTE: Exposed to fire on interior face only.</p>		
		45 min for 1 layer 5/8 in. 1 h for 2 layers 1/2 in. 1-1/2 h for 2 layers 5/8 in. 2 h for 3 layers 1/2 in. 2 h for 2 layers 3/4 in.	- - - - -

## Load Bearing Walls – Underwriters Laboratories Inc.

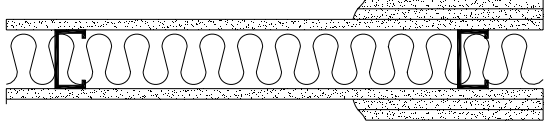
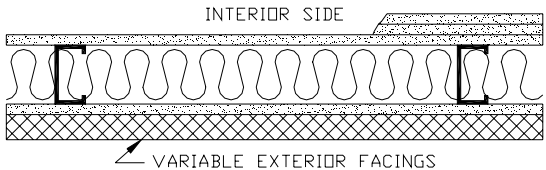
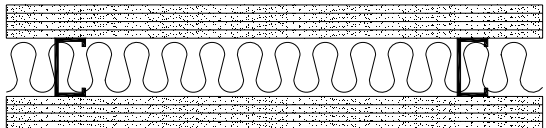
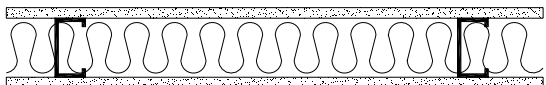
Source	Description	Fire Resistance Rating	Sound Transmission Class
UL U425 Interior Walls  a) USG811009 b) USG811006	<ul style="list-style-type: none"> <li>3 1/2" x 20 MSG steel stud spaced at 24" o.c.</li> <li>optional glass fiber or mineral wool insulation</li> <li>optional steel resilient channels spaced 24" o.c.</li> <li>gypsum board on each side (rating listed for thickness of gypsum and number of layers applied)</li> </ul> * 80% of Design Load		- 49 <sup>a</sup> (RFB 2") 48 <sup>b</sup> (RFB 2") - -
		45 min for 1 layer 1/2 in. 1 h for 1 layer 5/8 in. 1-1/2 h for 2 layers 1/2 in. * 2 h for 2 layers 5/8 in. 2 h for 3 layers 1/2 in. 2 h for 2 layers 3/4 in.	
UL U425 Exterior Walls  a) USG811009 b) USG811006	<ul style="list-style-type: none"> <li>3 1/2" x 20 MSG steel stud spaced at 24" o.c.</li> <li>glass fiber or mineral wool insulation</li> <li>optional steel resilient channels spaced 24" o.c.</li> <li>gypsum board on interior side (rating listed for thickness of gypsum and number of layers applied)</li> <li>1 layer of 1/2" or 5/8" exterior gypsum sheathing on exterior side</li> </ul> NOTE: Exposed to fire on interior face only.		- 49 <sup>a</sup> (RFB 2") 48 <sup>b</sup> (RFB 2") - -
		45 min for 1 layer 5/8 in. 1 h for 2 layers 1/2 in. 1-1/2 h for 2 layers 5/8 in. 2 h for 3 layers 1/2 in. 2 h for 2 layers 3/4 in.	
UL U426	<ul style="list-style-type: none"> <li>3 1/2" x 20 MSG steel stud spaced at 24" o.c.</li> <li>optional mineral wool or spray applied cellulose insulation</li> <li>4 layers of 1/2" gypsum board on each side</li> </ul>		-
		3 h	-
UL U432	<ul style="list-style-type: none"> <li>3 1/2" x 20 MSG steel stud spaced at 24" o.c.</li> <li>optional glass fiber or mineral wool insulation</li> <li>5/8" gypsum board on each side</li> </ul>		-
		1 h	-

## Load Bearing Walls – Underwriters Laboratories Inc.

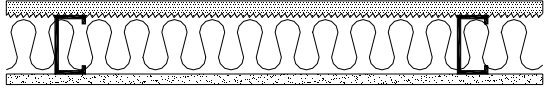
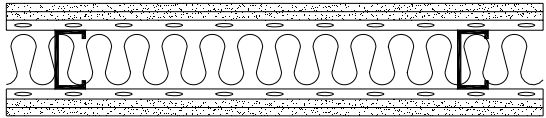
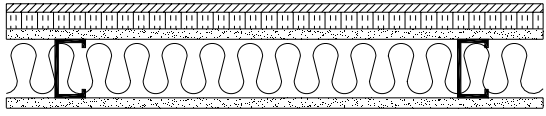
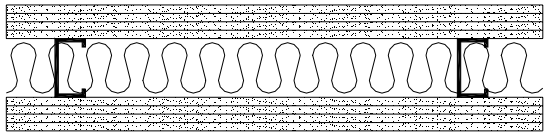
Source	Description	Fire Resistance Rating	Sound Transmission Class
UL U434	<ul style="list-style-type: none"> <li>3 1/2" x 20 MSG steel stud spaced at 24" o.c.</li> <li>optional glass fiber or mineral wool insulation</li> <li>5/8" gypsum board on one side</li> <li>metal lath and 2 coat 7/8" portland cement plaster</li> </ul>		
		1 h	<50* (RFB 3 1/2")
UL U440  a) USG811009 b) SA840715	<ul style="list-style-type: none"> <li>3 1/2" x 20 MSG steel stud spaced at 24" o.c.</li> <li>optional steel resilient channels spaced 24" o.c.</li> <li>optional mineral wool insulation</li> <li>2 layers of 1/2" gypsum board on each side</li> </ul>		
		1 h	49 <sup>a</sup> (NRC RFB 2") 51 <sup>b</sup> (one RC NI)
UL U460	<ul style="list-style-type: none"> <li>3 1/2" x 20 MSG steel stud spaced at 24" o.c.</li> <li>3 1/2" mineral wool insulation</li> <li>5/8" gypsum board on interior side</li> <li>5/8" gypsum sheathing on exterior side</li> <li>1" rigid polystyrene or polyisocyanurate insulation on exterior side</li> <li>1/2" plywood sheathing on exterior side</li> </ul>		
		1 h	-
UL U462	<ul style="list-style-type: none"> <li>3 1/2" x 20 MSG steel stud spaced at 24" o.c.</li> <li>optional mineral wool insulation</li> <li>4 layers of 1/2" gypsum board on each side</li> </ul>		
		3 h	-

\* Estimated value as per Warnock (2008)

## Load Bearing Walls – Underwriters Laboratories Inc.

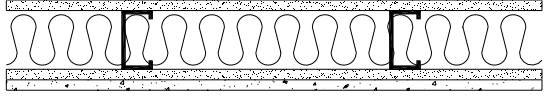
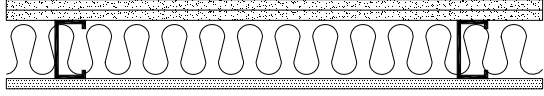
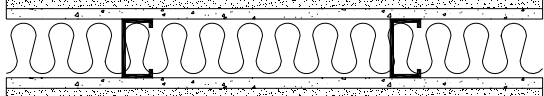
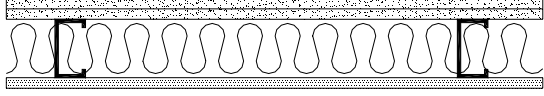
Source	Description	Fire Resistance Rating	Sound Transmission Class
UL U473	<ul style="list-style-type: none"> <li>• 3 1/2" x 20 MSG steel stud spaced at 16" o.c.</li> <li>• min 3" insulation</li> <li>• 1 layer 5/8" gypsum board on one side</li> <li>• 1 layer 5/8" gypsum board and 1 layer 1/2" or 5/8" cementitious board on other side</li> </ul>		
		1 h	<50* (CEMBRD 1/2" RFB 3")
UL U477	<ul style="list-style-type: none"> <li>• 3 5/8" x 1 5/8" x 20 MSG steel stud spaced at 24" o.c.</li> <li>• 3 1/2" mineral wool or spray applied cellulose insulation</li> <li>• 2 layers 5/8" gypsum board on one side</li> <li>• 1 layer 0.591" (15 mm) thick mineral and fiber board on other side</li> </ul>		
		2 h	-
UL U485	<ul style="list-style-type: none"> <li>• 3 1/2" x 20 MSG steel studs spaced at 16" o.c.</li> <li>• 3" min "Thermafiber" insulation</li> <li>• inner layer 1/2" or 5/8" cementitious board and outer layer 5/8" thick gypsum board on either side</li> </ul>		
		1 h	-
UL U487	<ul style="list-style-type: none"> <li>• 3 5/8" x 1 5/8" x 20 MSG steel stud spaced at 24" o.c.</li> <li>• 3" mineral wool insulation</li> <li>• 2 layers 5/8" gypsum board on one side</li> <li>• 1 layer 17 mm thick mineral and fiber board on other side</li> </ul>		
		1 h	<50*

\* Estimated value as per Warnock (2008)

## Load Bearing Walls – Underwriters Laboratories Inc.

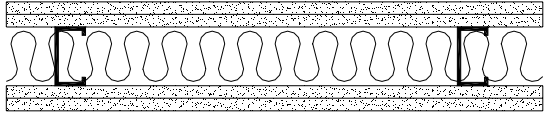
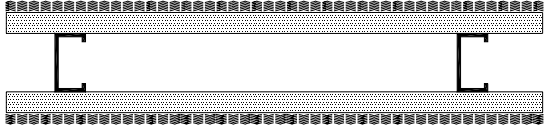
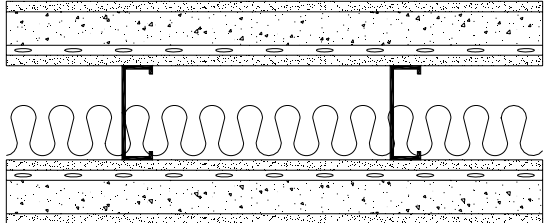
Source	Description	Fire Resistance Rating	Sound Transmission Class
UL U490	<ul style="list-style-type: none"> <li>• 3 1/2" x 1 5/8" x 20 MSG steel stud spaced at 24" o.c.</li> <li>• 3" mineral wool insulation for 3h</li> <li>• 3" mineral wool insulation with minimum 4 pcf for 4h</li> <li>• 2 layers 3/4" gypsum board on each side</li> </ul>		
		3 h 4 h	<50* <50*
UL U530	<ul style="list-style-type: none"> <li>• 3 5/8" x 1 3/4" x 20 MSG steel stud spaced at 24" o.c.</li> <li>• 1 layer 1 7/32" mineral and fiber board designated "Type Fire Therm" by GeoBond International on each side</li> <li>• diamond mesh expanded steel lath on each side</li> <li>• 1 layer 5/8" spray-applied fire resistive material designated "Type Thermal Mix" by GeoBond International on each side</li> </ul>		
		4 h	-
UL V415	<ul style="list-style-type: none"> <li>• 5 5/8" x 1 5/8" x 20 MSG steel stud spaced at 16" o.c.</li> <li>• 3 1/2" mineral wool or spray applied cellulose insulation</li> <li>• inner layer 5/8" gypsum board on each side</li> <li>• hat shaped furring channels spaced 24" o.c. on each side</li> <li>• 2" structural cement fiber units designated "Fibrochahl" or "Fibroplank" on each side</li> <li>• outer layer 5/8" gypsum board on each side</li> </ul>		
		2 h	-

## Load Bearing Walls – Underwriters Laboratories Inc.

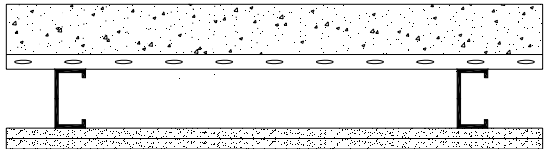
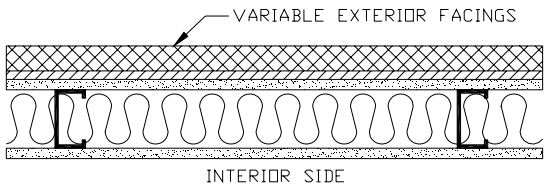
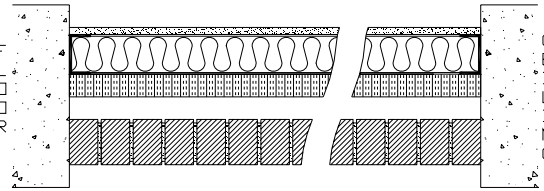
Source	Description	Fire Resistance Rating	Sound Transmission Class
UL V420	<ul style="list-style-type: none"> <li>• 3 1/2" x 20 MSG steel stud spaced at 24" o.c.</li> <li>• min 3" thick and max 2' wide precast autoclaved aerated concrete panels on one side</li> <li>• 7/8" furring channels spaced 24" o.c. on one side</li> <li>• 2 layers of 5/8" gypsum board on other side</li> </ul>		
		2 h	-
UL V432	<ul style="list-style-type: none"> <li>• 3 1/2" x 20 MSG steel stud spaced at 24" o.c.</li> <li>• glass fiber or mineral wool insulation</li> <li>• 5/8" gypsum sheathing on exterior side</li> <li>• optional min 7/16" wood structural panel sheathing on exterior side</li> <li>• 5/8" gypsum board on interior side</li> </ul> <p>NOTE: Exposed to fire on interior face only.</p>		
		1 h	-
UL V434	<ul style="list-style-type: none"> <li>• 3 1/2" x 20 MSG steel stud spaced at 24" o.c.</li> <li>• 3 1/2" glass fiber or mineral wool insulation</li> <li>• 1 layer 5/8" gypsum board on one side</li> <li>• 1 layer max 2" foamed plastic board on other side</li> <li>• 4" brick veneer</li> </ul>		
		1 h	-

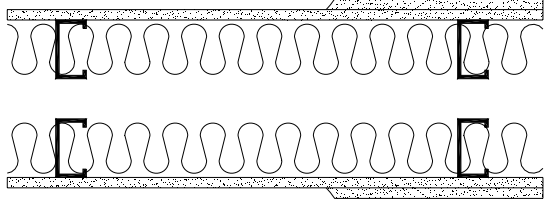
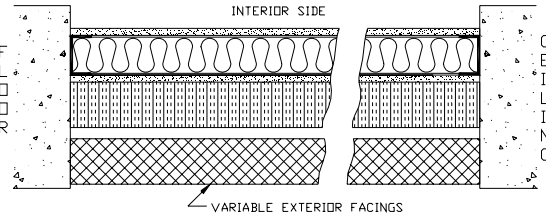
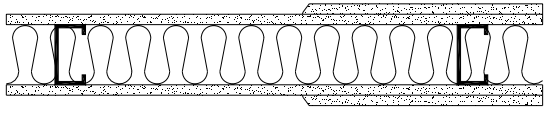

## Load Bearing Walls – Underwriters Laboratories Inc.

Source	Description	Fire Resistance Rating	Sound Transmission Class
UL V446	<ul style="list-style-type: none"> <li>double wall system with 3 1/2" x 1 5/8" x 0.034" thick galv steel stud spaced at 24" o.c.</li> <li>any glass fiber insulation with UL Classification Marking with min. density of 0.5 pcf</li> <li>1 or 2 layers of 5/8" gypsum board on each side</li> </ul> <p>** 80% of Design Load</p>		
		<p>**1 h for 1 - 5/8"</p> <p>2 h for 2 - 5/8"</p>	<p>58* (AIR 1")</p> <p>59* (AIR 2")</p> <p>68* (AIR 1")</p> <p>69* (AIR 2")</p>
UL V454	<ul style="list-style-type: none"> <li>3 1/2" x 20 MSG steel studs spaced at 24" o.c.</li> <li>optional glass fiber or mineral wool insulation filling stud cavity</li> <li>1 layer 5/8" gypsum board on each side</li> <li>1 layer max 4" foamed plastic board on one side</li> </ul>		
		1 h	-
UL V457	<ul style="list-style-type: none"> <li>3 5/8" x 1 5/8" x 20 MSG <b>proprietary</b> steel studs (Marino\WARE or Rotary Press Systems Inc.) spaced at 24" o.c.</li> <li>3 1/2" glass fiber insulation with min. density of 1.0 pcf</li> <li>1 hour - 1 layer 5/8" gypsum board on each side</li> <li>2 hour – 2 layers 5/8" gypsum board on each side</li> </ul>		
		<p>1 h</p> <p>2 h</p>	-

\* Estimated value as per Warnock (2008)

**Load Bearing Walls – Underwriters Laboratories Inc.**

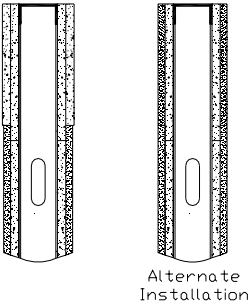
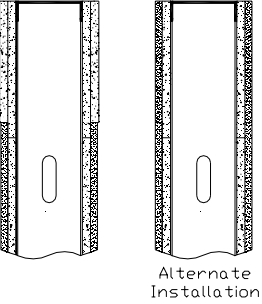
Source	Description	Fire Resistance Rating	Sound Transmission Class
UL V465	<ul style="list-style-type: none"> <li>• 3 1/2" x 1 5/8" x 20 MSG steel stud spaced at 24" o.c.</li> <li>• 3 1/2" nominal thickness glass fibre insulation friction fit in stud cavity</li> <li>• 3/4" thick structural cement-fibre units, designated "Fortacrete", one layer on each side and two layers on each side of stud top wall</li> <li>• 5/8" gypsum board, face layer on each side</li> </ul> <p>Alternate Installation</p> <ul style="list-style-type: none"> <li>• 3/4" thick structural cement-fibre units, designated "Fortacrete", one layer on each side</li> <li>• 5/8" gypsum board, entire face layer on each side</li> </ul>	 <p style="text-align: center;">Vertical Section</p>	-
UL V471	<ul style="list-style-type: none"> <li>• 6" x 1 5/8" x 18 MSG steel stud spaced at 24" o.c.</li> <li>• 5 1/2" nominal thickness glass fibre insulation friction fit in stud cavity</li> <li>• 3/4" thick structural cement-fibre units, designated "Fortacrete", one layer on each side and two layers on each side of stud top wall</li> <li>• 5/8" gypsum board, face layer on each side</li> </ul> <p>Alternate Installation</p> <ul style="list-style-type: none"> <li>• 3/4" thick structural cement-fibre units, designated "Fortacrete", one layer on each side</li> <li>• 5/8" gypsum board, entire face layer on each side</li> </ul>	 <p style="text-align: center;">Vertical Section</p>	-
		<b>2 h</b>	-
		<b>3 h</b>	-

## Load Bearing Walls – Gypsum Association

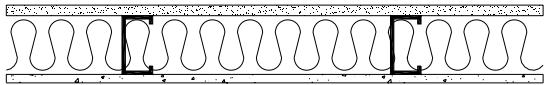
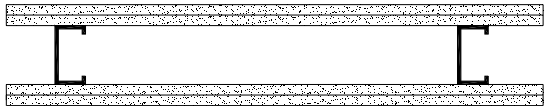
Source	Description	Fire Resistance Rating	Sound Transmission Class
GA WP1035	<ul style="list-style-type: none"> <li>• 3 1/2" x 20 gage steel stud spaced at 16" o.c.</li> <li>• 3" mineral fiber insulation</li> <li>• 1 layer 5/8" Type X gypsum board on one side</li> <li>• 1 layer 1/2" cementitious board on other side</li> </ul>		
		1 h	<50*
GA WP1716  NGC 2250	<ul style="list-style-type: none"> <li>• 3 1/2" x 20 gage steel stud spaced at 24" o.c.</li> <li>• 2 layers 5/8" Type X gypsum board on each side</li> </ul>		
		2 h	40 to 44

\* Estimated value as per Warnock (2008)

# **ROOF/CEILING ASSEMBLIES**

## Roof/Ceiling – Underwriters’ Laboratories of Canada

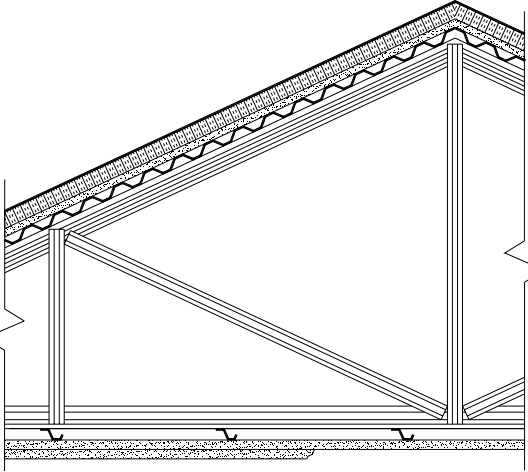
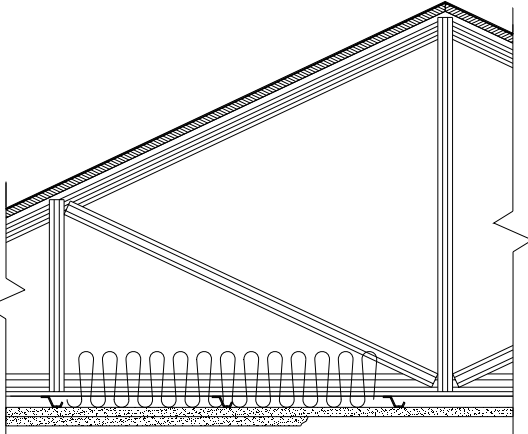
Source	Description	Fire Resistance Rating
<p>ULC R500</p>	<ul style="list-style-type: none"> <li>• roof covering</li> <li>• foamed plastic insulation boards, 1" for 1h, 2" for 1½ h &amp; 4" for 2h</li> <li>• gypsum sheathing min. 12.7 mm thick</li> <li>• steel roof deck corrugated or fluted, min. 0.76 mm thick</li> <li>• trusses spaced a max. 1220 mm o.c.</li> <li>• <b>proprietary</b> pre-fabricated light gauge steel truss system, Ultra-Span by Aegis Metal Framing</li> <li>• resilient or furring channels spaced 406 mm o.c.</li> <li>• 1 &amp; 1½ hour - 1 layer of 15.9 mm gypsum board on ceiling side</li> <li>• 2 hour - 2 layers of 15.9 mm gypsum board on ceiling side</li> </ul>	<div style="text-align: center;">  </div> <div style="text-align: center; margin-top: 10px;"> <p>1 h 1-½ h 2 h</p> </div>
<p>ULC R501</p>	<ul style="list-style-type: none"> <li>• roof covering</li> <li>• nom. 18 mm thick wood structural panels</li> <li>• trusses spaced a max. of 1220 mm o.c.</li> <li>• <b>proprietary</b> pre-fabricated light gauge steel truss system, Ultra-Span by Aegis Metal Framing</li> <li>• min. 241 mm thick glass fibre insulation for 1½h, any thickness mineral wool or glass fibre insulation for 1 h, optional</li> <li>• resilient or furring channels spaced 406 mm o.c.</li> <li>• 1 hour - 1 layer of 15.9 mm gypsum board on ceiling side</li> <li>• 1½ hours - 2 layers of 15.9 mm gypsum board on ceiling side</li> </ul>	<div style="text-align: center;">  </div> <div style="text-align: center; margin-top: 10px;"> <p>1 h 1-½ h</p> </div>

## Roof/Ceiling – Underwriters Laboratories Inc.

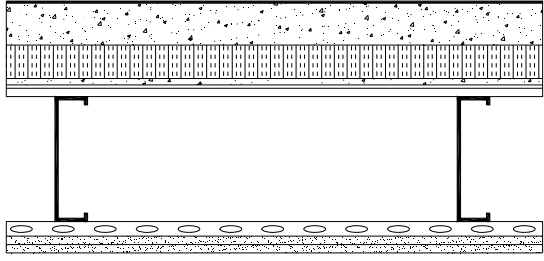
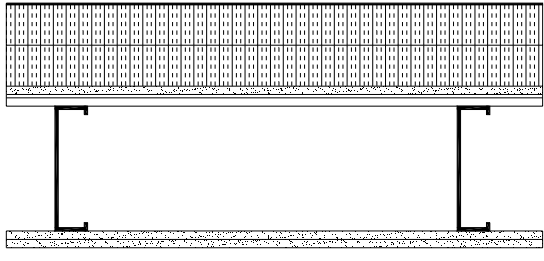
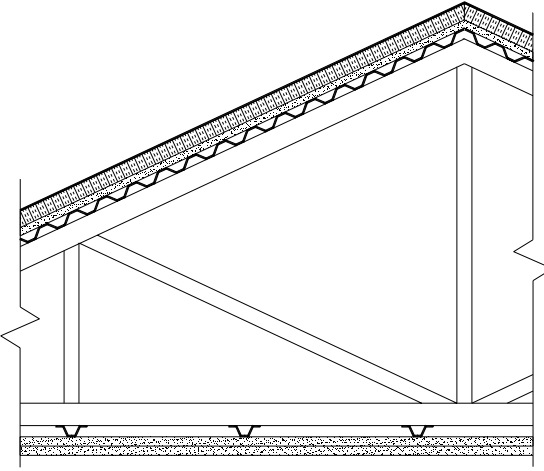
Source	Description	Fire Resistance Rating
UL P511	<ul style="list-style-type: none"> <li>• crushed stone &amp; roof covering</li> <li>• insulating concrete, min. 2"</li> <li>• foamed plastic insulation boards, thickness 1" to 8"</li> <li>• 28 MSG roof deck, <math>\frac{9}{16}</math>" deep</li> <li>• <math>7\frac{1}{4}</math>" x 18 MSG steel roof joist spaced 24" o.c.</li> <li>• furring channels spaced 24" o.c.</li> <li>• 2 layers of <math>\frac{1}{2}</math>" gypsum board</li> </ul>	 <p style="text-align: center;">1 h</p>
UL P512	<ul style="list-style-type: none"> <li>• roof covering</li> <li>• 2 layers of <math>2\frac{7}{16}</math>" mineral &amp; fiber boards</li> <li>• gypsum sheathing <math>\frac{1}{2}</math>" thick</li> <li>• 28 MSG roof deck, <math>\frac{9}{16}</math>" deep</li> <li>• <math>7\frac{1}{4}</math>" x 18 MSG steel roof joist spaced 24" o.c.</li> <li>• 2 layers of <math>\frac{1}{2}</math>" gypsum board</li> </ul>	 <p style="text-align: center;">1 h</p>
UL P515	<ul style="list-style-type: none"> <li>• roof covering</li> <li>• foamed plastic, mineral wool, glass fiber or perlite insulation boards, 1" min. thickness and no limit on max. overall thickness</li> <li>• gypsum sheathing <math>\frac{1}{2}</math>" thick</li> <li>• steel roof deck corrugated or fluted, min. 28 MSG</li> <li>• trusses spaced a max. 24" or 48" o.c.</li> <li>• truss chord &amp; web sections designed to AISI Specifications</li> <li>• resilient or furring channels spaced 24" o.c.</li> <li>• 2 layers of <math>\frac{5}{8}</math>" gypsum board on ceiling side</li> </ul>	 <p style="text-align: center;">1 h</p>

Roof/Ceiling – Underwriters Laboratories Inc.

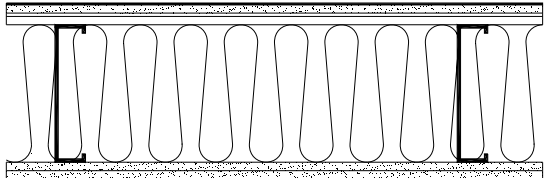
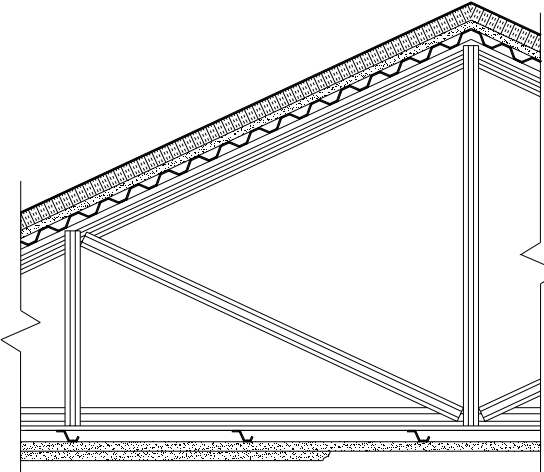
Source	Description	Fire Resistance Rating
UL P518	<ul style="list-style-type: none"> <li>• roof covering</li> <li>• gypsum sheathing ½” thick</li> <li>• 28 MSG roof deck, 9/16” deep</li> <li>• 8” x 18 MSG steel roof joist spaced at 24” o.c.</li> <li>• 8” thick glass fiber insulation</li> <li>• 2 layers of ½” gypsum board</li> </ul>	 <p style="text-align: center;">1 h</p>
UL P521	<ul style="list-style-type: none"> <li>• roof covering</li> <li>• foamed plastic insulation boards, 1” for 1h, 2” for 1½ h &amp; 4” for 2h</li> <li>• gypsum sheathing min. ½” thick</li> <li>• steel roof deck corrugated or fluted, min. 22 MSG</li> <li>• trusses spaced a max. 48” o.c.</li> <li>• <b>proprietary</b> pre-fabricated light gauge steel truss system, Ultra-Span by Aegis Metal Framing</li> <li>• resilient or furring channels spaced 16” o.c.</li> <li>• 1 &amp; 1½ hour - 1 layer of 5/8” gypsum board on ceiling side</li> <li>• 2 hour - 2 layers of 5/8” gypsum board on ceiling side</li> </ul>	 <p style="text-align: center;">1 h 1-½ h 2 h</p>

Roof/Ceiling – Underwriters Laboratories Inc.

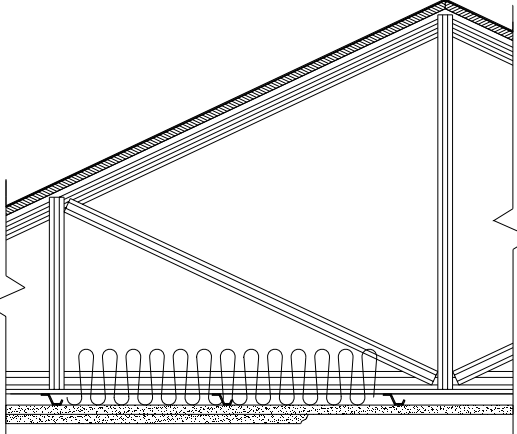
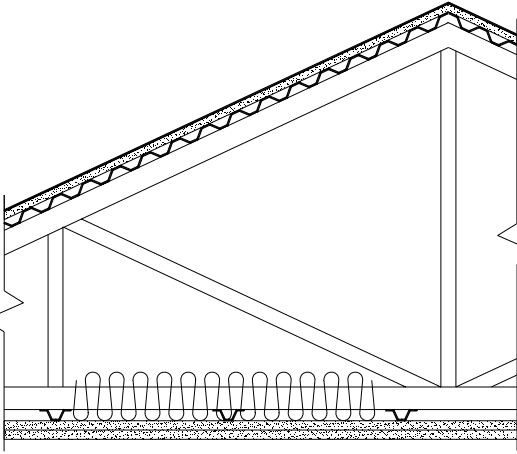
Source	Description	Fire Resistance Rating
<p>UL P523</p>	<ul style="list-style-type: none"> <li>• roof covering</li> <li>• nom. <math>\frac{23}{32}</math>" thick wood structural panels</li> <li>• trusses spaced a max. of 48" o.c.</li> <li>• <b>proprietary</b> pre-fabricated light gauge steel truss system, Ultra-Span by Aegis Metal Framing</li> <li>• min. 9½" thick glass fiber insulation for 1½h, any thickness mineral wool or glass fiber insulation for 1 h, optional</li> <li>• resilient or furring channels spaced 16"o.c.</li> <li>• 1 hour - 1 layer of 5⁄8" gypsum board on ceiling side</li> <li>• 1½ hours - 2 layers of 5⁄8" gypsum board on ceiling side</li> </ul>	 <p style="text-align: center;">1 h 1-½ h</p>
<p>UL P524</p>	<ul style="list-style-type: none"> <li>• roof covering</li> <li>• gypsum sheathing ½" thick</li> <li>• steel roof deck corrugated or fluted, min. 28 MSG</li> <li>• trusses spaced a max. 24" or 48" o.c.</li> <li>• truss chord &amp; web sections designed to AISI Specifications</li> <li>• resilient or furring channels spaced 24"o.c.</li> <li>• 8" thick glass fiber insulation</li> <li>• 2 layers of 5⁄8" gypsum board on ceiling side</li> </ul>	 <p style="text-align: center;">1 h</p>

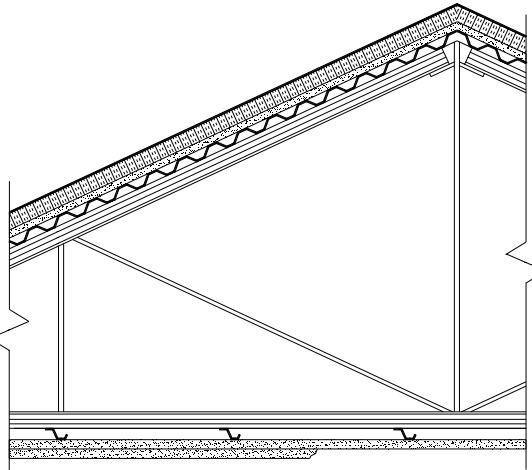
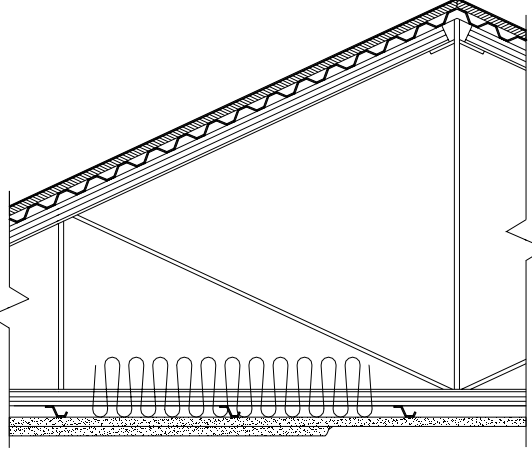

Roof/Ceiling – Underwriters Laboratories Inc.

Source	Description	Fire Resistance Rating
<p>UL P525</p>	<ul style="list-style-type: none"> <li>• roof covering</li> <li>• foamed plastic insulation boards, no minimum for 1h, 2" for 1½ h &amp; 4" for 2h</li> <li>• gypsum sheathing min. ½" thick</li> <li>• steel roof deck corrugated or fluted, min. 22 MSG</li> <li>• trusses spaced a max. 48" o.c.</li> <li>• <b>proprietary</b> pre-fabricated light gauge steel truss system, TrusSteel by Alpine Engineered Products, Inc.</li> <li>• resilient or furring channels spaced 16"o.c.</li> <li>• 1 &amp; 1½ hours - 1 layer of 5/8" gypsum board on ceiling side</li> <li>• 2 hours - 2 layers of 5/8" gypsum board on ceiling side</li> </ul>	<div style="text-align: center;">  </div> <div style="text-align: center; margin-top: 10px;"> <p>1 h 1-½ h 2 h</p> </div>
<p>UL P526</p>	<ul style="list-style-type: none"> <li>• roof covering</li> <li>• nom. 23/32" thick plywood sheathing</li> <li>• trusses spaced a max. 24" or 48" o.c.</li> <li>• <b>proprietary</b> pre-fabricated light gauge steel truss system, TrusSteel by Alpine Engineered Products, Inc.</li> <li>• resilient or furring channels spaced 16"o.c.</li> <li>• min. 9½" thick mineral wool or glass fiber insulation for 1½h, any thickness mineral wool or glass fiber insulation for 1 h, optional</li> <li>• 1 hour – 1 layer of 5/8" gypsum board on ceiling side</li> <li>• 1½ hours - 2 layers of 5/8" gypsum board on ceiling side</li> </ul>	<div style="text-align: center;">  </div> <div style="text-align: center; margin-top: 10px;"> <p>1 h 1-½ h</p> </div>

Roof/Ceiling – Underwriters Laboratories Inc.

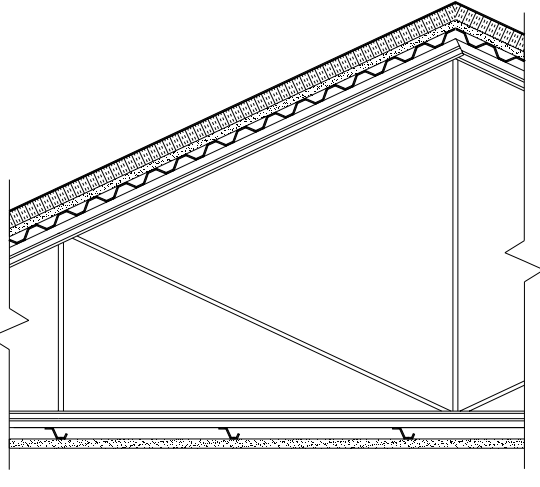
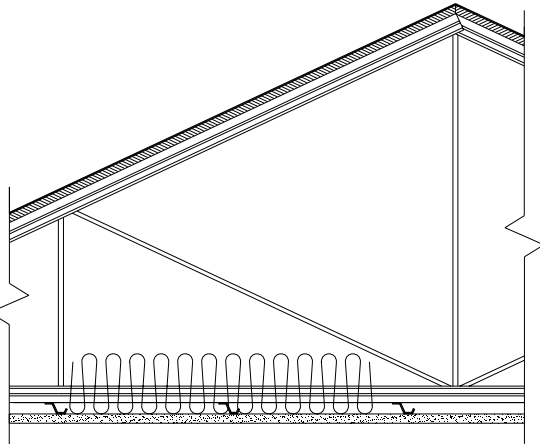
Source	Description	Fire Resistance Rating
<p>UL P527</p>	<ul style="list-style-type: none"> <li>• roof covering</li> <li>• foamed plastic insulation boards, no minimum for 1h &amp; 2" for 1½ h</li> <li>• gypsum sheathing min. ½" thick</li> <li>• steel roof deck corrugated or fluted, min. 22 MSG</li> <li>• trusses spaced a max. 48" o.c.</li> <li>• <b>proprietary</b> pre-fabricated light gauge steel truss system, Amkey System by Allied Studco</li> <li>• resilient channels spaced 16" o.c.</li> <li>• 1 layer of 5/8" gypsum board on ceiling side</li> </ul>	 <p style="text-align: center;">1 h 1-½ h</p>
<p>UL P528</p>	<ul style="list-style-type: none"> <li>• roof covering</li> <li>• nom. 23/32" thick plywood sheathing</li> <li>• trusses spaced a max. 24" or 48" o.c.</li> <li>• <b>proprietary</b> pre-fabricated light gauge steel truss system, Amkey System by Allied Studco</li> <li>• resilient channels spaced 16" o.c.</li> <li>• mineral wool or glass fiber insulation</li> <li>• 1 layer of 5/8" gypsum board on ceiling side</li> </ul>	 <p style="text-align: center;">1 h</p>

Roof/Ceiling – Underwriters Laboratories Inc.

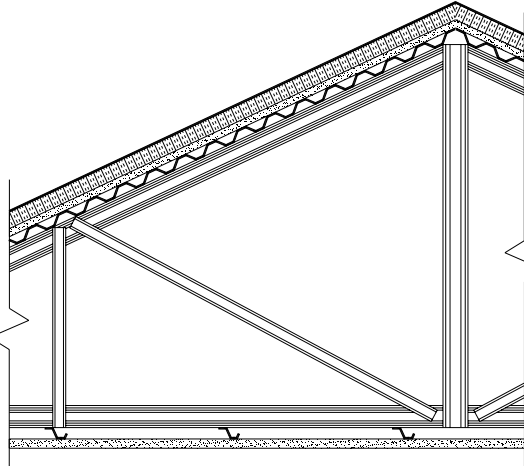
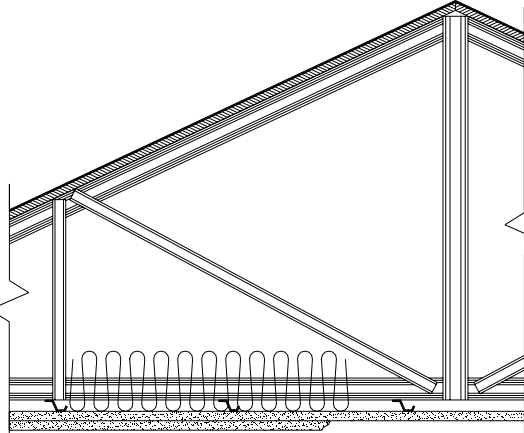
Source	Description	Fire Resistance Rating
<p>UL P532</p>	<ul style="list-style-type: none"> <li>• roof covering</li> <li>• foamed plastic insulation boards, no minimum for 1 h, 2" for 1½ h &amp; 3" for 2 h</li> <li>• gypsum sheathing min. ½" thick</li> <li>• steel roof deck corrugated or fluted, min. 22 MSG</li> <li>• trusses spaced a max. 48" o.c.</li> <li>• <b>proprietary</b> pre-fabricated light gauge steel truss system, Strong-Span by Hexaport International Ltd.</li> <li>• resilient channels spaced 16" o.c.</li> <li>• 1 layer of 5/8" gypsum board on ceiling side</li> </ul>	<div style="text-align: center;">  <p style="text-align: center;">1 h 1-½ h 2 h</p> </div>
<p>UL P534</p>	<ul style="list-style-type: none"> <li>• roof covering</li> <li>• nom. 23/32" thick wood structural panels</li> <li>• trusses spaced a max. 48" o.c.</li> <li>• <b>proprietary</b> pre-fabricated light gauge steel truss system, Strong-Span by Hexaport International Ltd.</li> <li>• resilient or furring channels spaced 16" o.c.</li> <li>• min. 9½" thick glass fiber insulation for 1½ h, any thickness mineral wool or glass fiber insulation for 1 h, optional</li> <li>• 1 hour - 1 layer of 5/8" gypsum board on ceiling side</li> <li>• 1½ hours - 2 layers of 5/8" gypsum board on ceiling side</li> </ul>	<div style="text-align: center;">  <p style="text-align: center;">1 h 1-½ h</p> </div>

## Roof/Ceiling – Underwriters Laboratories Inc.

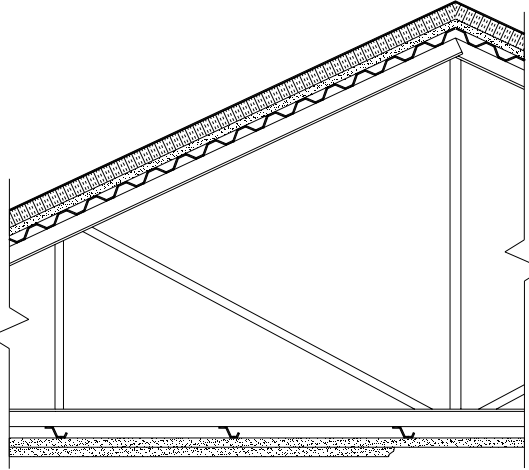
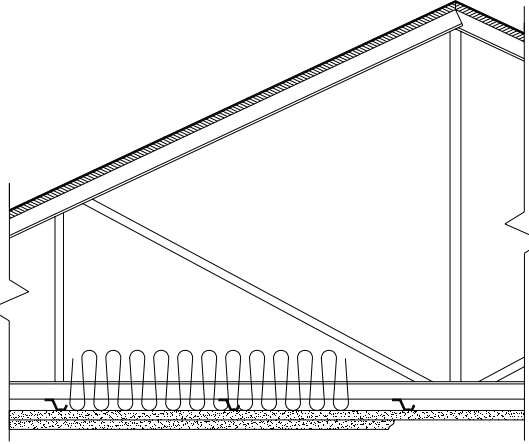
Source	Description	Fire Resistance Rating
<p>UL P536</p>	<ul style="list-style-type: none"> <li>• roof covering</li> <li>• foamed plastic insulation boards, no minimum for 1 h, 1" for 1½ h &amp; 2.6" for 2 h</li> <li>• gypsum sheathing min. ½" thick</li> <li>• steel roof deck corrugated or fluted, min. 22 MSG</li> <li>• trusses spaced a max. 48" o.c.</li> <li>• <b>proprietary</b> pre-fabricated light gauge steel truss system, Gus Truss by Nucon Steel Corporation</li> <li>• resilient channels spaced 16" o.c.</li> <li>• 1 &amp; 1½ hours - 1 layer of 5/8" gypsum board on ceiling side</li> <li>• 2 hours - 2 layers of 5/8" gypsum board on ceiling side</li> </ul>	 <p style="text-align: center;">1 h 1-½ h 2 h</p>
<p>UL P537</p>	<ul style="list-style-type: none"> <li>• roof covering</li> <li>• nom. 23/32" thick wood structural panels</li> <li>• trusses spaced a max. 48" o.c.</li> <li>• <b>proprietary</b> pre-fabricated light gauge steel truss system, Gus Truss by Nucon Steel Corporation</li> <li>• resilient or furring channels spaced 16" o.c.</li> <li>• min. 9½" thick glass fiber insulation for 1½ h, any thickness mineral wool or glass fiber insulation for 1 h, optional</li> <li>• 1 hour - 1 layer of 5/8" gypsum board on ceiling side</li> <li>• 1½ hours - 2 layers of 5/8" gypsum board on ceiling side</li> </ul>	 <p style="text-align: center;">1 h 1-½ h</p>

**Roof/Ceiling – Underwriters Laboratories Inc.**

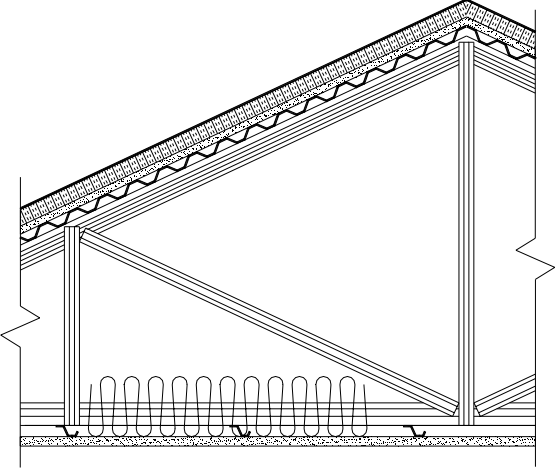
Source	Description	Fire Resistance Rating
<p>UL P540</p>	<ul style="list-style-type: none"> <li>• roof covering</li> <li>• foamed plastic, mineral wool, glass fiber or perlite insulation boards, no min. thickness and no limit on max. overall thickness</li> <li>• gypsum sheathing min. ½” thick</li> <li>• steel roof deck corrugated or fluted, min. 22 MSG</li> <li>• trusses spaced a max. 48” o.c.</li> <li>• <b>proprietary</b> pre-fabricated light gauge steel truss systems,               <ol style="list-style-type: none"> <li>1. Ultra-span by Aegis Metal Framing</li> <li>2. Amkey System by Allied Studco</li> <li>3. Versa-Truss by Dale/Incor</li> <li>4. Strong-Span by Hexaport International Ltd.</li> <li>5. Gus Truss by Nucon Steel Corporation</li> <li>6. TrusSteel by Alpine Engineered Products</li> </ol> </li> <li>• resilient or furring channels spaced 16”o.c.</li> <li>• any thickness mineral wool or glass fiber insulation</li> <li>• 1 layer of 5/8” gypsum board on ceiling side</li> </ul>	 <p style="text-align: center;">1 h</p>

## Roof/Ceiling – Underwriters Laboratories Inc.

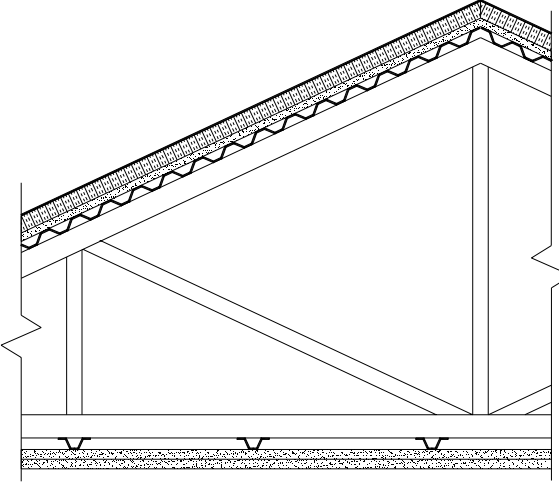
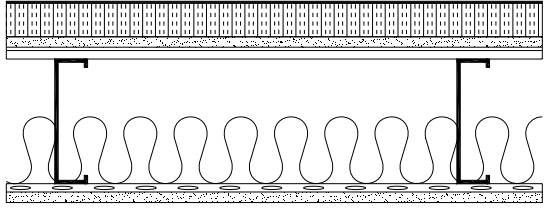
Source	Description	Fire Resistance Rating
UL P541	<ul style="list-style-type: none"> <li>• roof covering</li> <li>• foamed plastic, mineral wool, glass fiber or perlite insulation boards, 1" min. thickness and no limit on max. overall thickness</li> <li>• gypsum sheathing ½" thick</li> <li>• steel roof deck corrugated or fluted, min. 28 MSG</li> <li>• trusses spaced a max. 24" or 48" o.c.</li> <li>• truss chord &amp; web sections designed to AISI Specifications</li> <li>• resilient channels spaced 24" o.c.</li> <li>• 2 layers of 5/8" gypsum board on ceiling side</li> </ul>	 <p style="text-align: center;">1 h</p>
UL P546	<ul style="list-style-type: none"> <li>• roof covering</li> <li>• foamed plastic insulation boards, 1" min. thickness and no limit on max. overall thickness</li> <li>• gypsum board ½" or 5/8" thick</li> <li>• 22 MSG roof deck, 9/16" deep</li> <li>• 9¼" x 16 MSG <b>proprietary</b> steel joist (Dietrich Industries Inc.) spaced at 24" o.c.</li> <li>• resilient channels spaced 12" o.c.</li> <li>• any glass fiber insulation, min. 3½" and max. 6¼" thick</li> <li>• 1 layer of 5/8" gypsum board on ceiling side</li> </ul>	 <p style="text-align: center;">1 h</p>