

## JOIST END – ANGLE CLIPS FOR BAILEY FLOOR JOIST

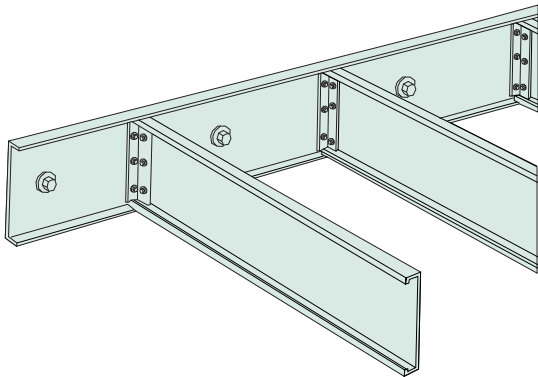

These clips are designed to connect floor joists to the rim joist at the perimeter of the floor, to headers at floor openings, and flush to beams.



### THESE CLIPS CAN ALSO BE USED TO:

- Connect lintels to king studs at openings in loadbearing walls
- Attach solid blocking to adjacent joists for bridging
- Connect miscellaneous framing components
- Act as a bridging clip for 10" studs

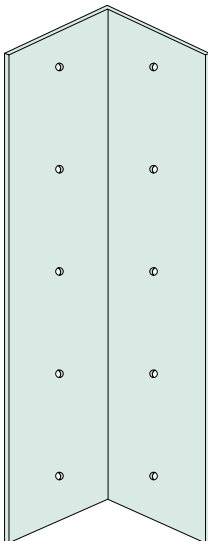

### PRODUCT FEATURES:

- These clips are designed to fit inside of the joist and allow 1/4" clearance at both ends
- The leg length will not interfere with the flange of the joist
- An edge distance of more than 1/2" to the screw hole is maintained
- The holes are located to provide easy access for the installation of the screws
- Adequate number of holes are provided
- Pre-punched holes provided for #10 screws

NOTE: These clips are not recommended for use as a bearing stiffener. For bearing stiffeners use Bailey web stiffeners



## DIMENSIONS AND INFORMATION ON THE JOIST END – ANGLE CLIP FOR 8", 10", 12" AND 14" JOISTS

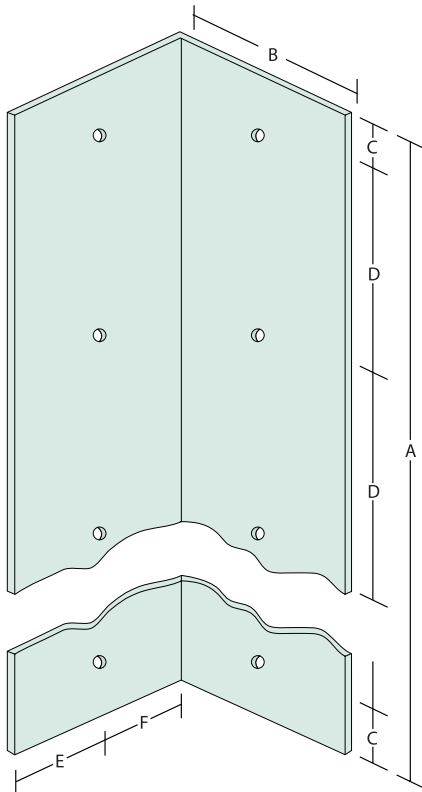

<b>A</b>	7.5"	9.5"	11.5"	13.5"
<b>B</b>	1.375"	1.375"	1.375"	1.375"
<b>C</b>	0.75"	0.75"	0.75"	0.75"
<b>D</b>	2.0"	2.0"	2.0"	2.0"
<b>E</b>	0.688"	0.688"	0.688"	0.688"
<b>F</b>	0.688"	0.688"	0.688"	0.688"

**STEEL** - G60 GALVANIZED  
 - THICKNESS 0.054"  
 - GRADE 33 K.S.I. (minimum yield)

**HOLE SIZE** - 0.160"

**PACKAGING** - 25 PCS/CTN

**DESIGNED FOR USE WITH #10 SCREWS**

**OTHER PROFILES AND MATERIALS  
 AVAILABLE ON REQUEST**

### ORDERING INFORMATION

JOIST DEPTH	CLIP LENGTH	PART #
8"	7 1/2"	JC 800-54
10"	9 1/2"	JC 1000-54
12"	11 1/2"	JC 1200-54
14"	13 1/2"	JC 1400-54

### BAILEY METAL PRODUCTS LIMITED

**MONTREAL**  
 LES PRODUITS METALLIQUES BAILEY LTEE  
 5890 Avenue Andover  
 Ville Mont-Royal QC H4T 1H4  
 Tel: (514) 735 3455  
 (800) 263 3455  
 Fax: (514) 735 5052

**TORONTO**  
 One Caldari Road  
 Concord ON L4K 3Z9  
 Tel: (905) 738 6738  
 (800) 668 2154  
 Fax: (905) 738 5712

**CALGARY**  
 2515 Centre Avenue S.E.  
 Calgary AB T2A 2L1  
 Tel: (403) 248 3536  
 (800) 665 2013  
 Fax: (403) 248 0288

**EDMONTON**  
 5710 Roper Road N.W., Suite 101  
 Edmonton AB T6B 3G7  
 Tel: (780) 462 5757  
 (800) 563 1751  
 Fax: (780) 465 3791

**VANCOUVER**  
 7715 Anvil Way  
 Surrey BC V3W 6A2  
 Tel: (604) 590 5100  
 (800) 818 2666  
 Fax: (604) 599 5371